

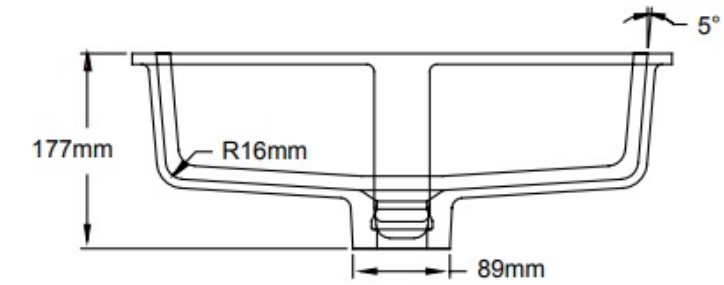

Manufactured by Gemstone in the U.S.A

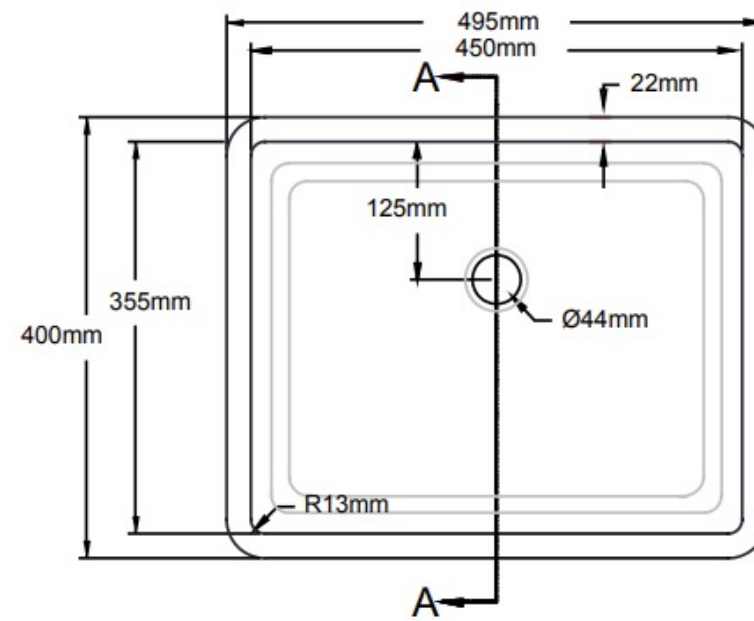

AUSTARON
SURFACES

AUS: 17/30 Heathcote Rd, Moorebank NSW 2170
 NZ: 94 Nevay Rd, Karaka Bays Wellington 6620
 phone: 02 9822 7055
 email: sales@austaron.com.au
 web: austaron.com.au

TITLE **REFINE BASIN COLLECTION**
Refine 1814-V (Accessible Design)

DWG NO.
 1814-V DXF

ADDITIONAL DETAILS

W: 495mm
 D: 400mm
 H: 177mm

COLOUR AVAILABILITY: Alpine White