

Thermoforming

22.1 Material Preparation

Material preparation is very important for successful thermoforming of Staron®.

1. Cut all pieces to their required dimensions.

➔ **Note**

Allow for material shrinkage and expansion during thermoforming.

2. Sand all material to a matte finish to remove any chips and scratches from edge that may cause tearing during forming. When designing, the minimum inside radius thermoformed as per Staron® thickness is as follows.

Sheet Thickness	Minimum Inside Radius	Remarks
6 mm (¼")	25 mm (1")	Solid, Sanded
	102 mm (4")	Aspen, Pebble
12 mm (½")	76 mm (3")	Solid, Sanded
	127 mm (5")	Aspen, Pebble
	203 mm (8")	Quarry, Talus, Breccia, Metallic

[22.1 - A]

Quarry, Talus, Breccia, Metallic and Tempest are not recommended for thermoforming.

If the sheet is bent to a radius smaller than the above values, the sheet may crack, craze, or whiten externally and / or internally.

22.2 Mold Preparation

Accurate molds must be prepared before heating materials.

Make molds from plywood or M.D.F. board in male / female sections to hold the heated sheet in the desired shape.

1. Cut the male and female mold from good quality plywood or M.D.F. board with a jig saw or router. The mold surface must be smooth and in good quality without any defects to prevent them from transferring onto the face of the Staron® to be thermoformed.
2. The internal part of the male and female molds must be supported to endure pressure.
3. Do not use metal or solid wood, because these materials might absorb heat and slow the thermoforming and cooling process.

22.3 Oven

Having the right oven is essential for thermoforming. The oven has to be heated evenly (homogeneously) to get good result.

- The oven has to be designed for Staron® sheets and be heated to the same temperature at the same time.
- The oven has to be able to fully enclose the sheet. Heat it in a consistent and constant fashion with accurate and predictable control.

22.4 Oven Calibration

Oven must be correctly prepared and calibrated.

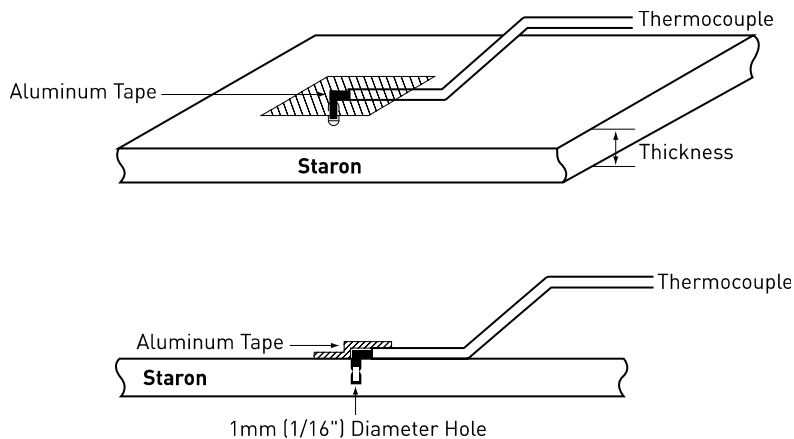

[22.4 - A]

- Drill a 1.5mm (1/16") diameter hole halfway into a test piece of Staron®.
- Insert a thermocouple wire in the hole and the other thermocouple on the surface. The thermocouples should be covered with aluminum tape. To check two different temperatures.
- Check when the temperature in the hole reaches 293~302°F(145-150°C) and on the surface below 320°F (160°C) simultaneously. This will be the most effective time / temperature for your oven.
- Keep this profile during thermoforming.
- When the temperature in the hole reaches 293~302°F(145-150°C) and if the temperature on the surface is higher than 320°F(160°C), the heating power is too strong. Reduce the heating power.
- Remove the piece from the oven and allow it to cool until the thermometer reaches 180°F(82°C).
- Check the cool-down time.

22.5 Thermoforming

Thermoforming of Staron®

Staron® must be heated to a temperature between 293°F(145°C) and 330°F(165°C) for thermoforming. Lower temperatures may crack and whiten the Staron® material and higher temperatures will blister, whiten, or crack the material.

Heat up time will depend on oven design and the size of the piece to be thermoformed.

➔ Note

Uniformly heat the entire piece to prevent problems.

Recommended Time and Temperature guide is listed below.

However, running a test on a scrap piece is highly recommended to find the best time / temperature for the oven.

Sheet Thickness	Oven temperature	Heat up time
6 mm (¼")	302°F(150°C)	30~60 min
	347°F(175°C)	15~30 min
12.3mm (½")	302°F(150°C)	45~80 min
	347°F(175°C)	25~60 min

[22.5 - A]

▶ TIP

Temperature and time may vary depending on the oven.
It is highly recommended to test before final fabrication

22.6 Thermoforming Checklist

- Oven temperature should never exceed 347°F(175°C).
- Oven temperature exceeding 347°F(175°C) may overheat the surface of the sheet causing uneven distribution, causing problems.
- Before thermoforming Staron® sheet, calibrate the oven with a sample piece.
- Pre-heat the oven to the desired temperature.
- Place the piece of Staron® in the oven and start the timer.
- At the end of the calibrated time, remove the piece from the oven.
- Place the piece in the mold and clamp it securely.
- Reset the timer.
- At the end of the calibrated cool-down time, remove the piece from the mold and keep it under the atmosphere to cool to room temperature.