

PLAN SCALE 1:10 A3

FABRICATION AND INSTALLATION

- Manufacture as per fabrication requirements
- Recommended 1 waste outlet for every 2 taps
- Weight of unit approx. kg per lineal metre
- Builder to ensure suitable wall strength to support



COLOUR: Staron Supreme Dawn

SPECIFICATION DETAILS

- AUS designed and fabricated in every state STARON:
2/3 natural mineral and 1/3 acrylic
Silica and polyester FREE
Greenguard & Greenguard Gold certified
10 Year Warranty
- Unit available in all Staron colours, including mixed combinations
- Aluminium grate supplied in:
satin silver grey
satin black
mill finish (allowing further custom anodising/powder coating)
- All dimensions flexible
- Adapt design to suit joinery units
- Modify form to accommodate:
disability rails
parcel shelves
towel/soap dispensers
- Refine **1712-V** & **B3192** Dyson compatible, refer to sinks for specification details

staron
Solid Surfaces

AUSTARON
SURFACES

AUS: 17/30 Heathcote Rd Moorebank NSW 2170
NZ: 94 Nevay Rd, Karaka Bays Wellington 6620
phone: 02 9822 7055
email: sales@austaron.com.au
web: austaron.com.au

staron
Example

TITLE **STARON GRADIENT AIR 5P WITH PARCEL SHELF**
SOLID SURFACE WASHPLANE - FLEXIBLE DIMENSIONS
COMPATIBLE WITH WALL MOUNT DYSON AIRBLADE
DWG NO. STARON EXAMPLE - 004

DRAWN IV
DATE 01.04.20
CHK'D AS

DO NOT SCALE DRAWING
SHEET 1 OF 2
A3

DESIGN REMAINS PROPERTY OF AUSTARON SURFACES AND CAN ONLY BE USED WHEN SPECIFYING STARON SOLID SURFACE.

Architect to determine design suitability.
Contact your Staron representative for any colour samples or technical information.

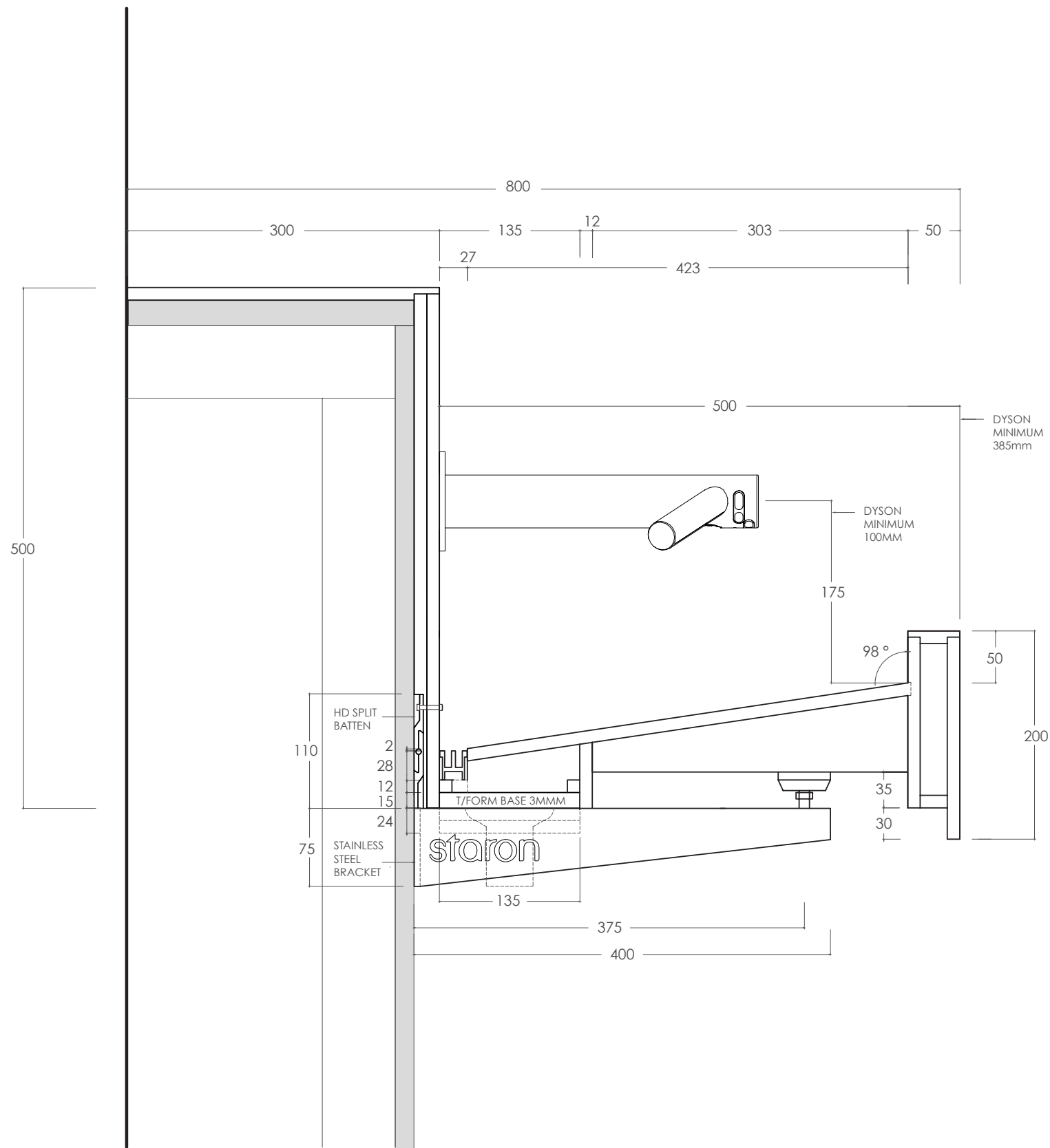

SECTION SCALE 1:5 A3

STARON SUPPLIED COMPONENTS

Components only available for use with Staron designs.

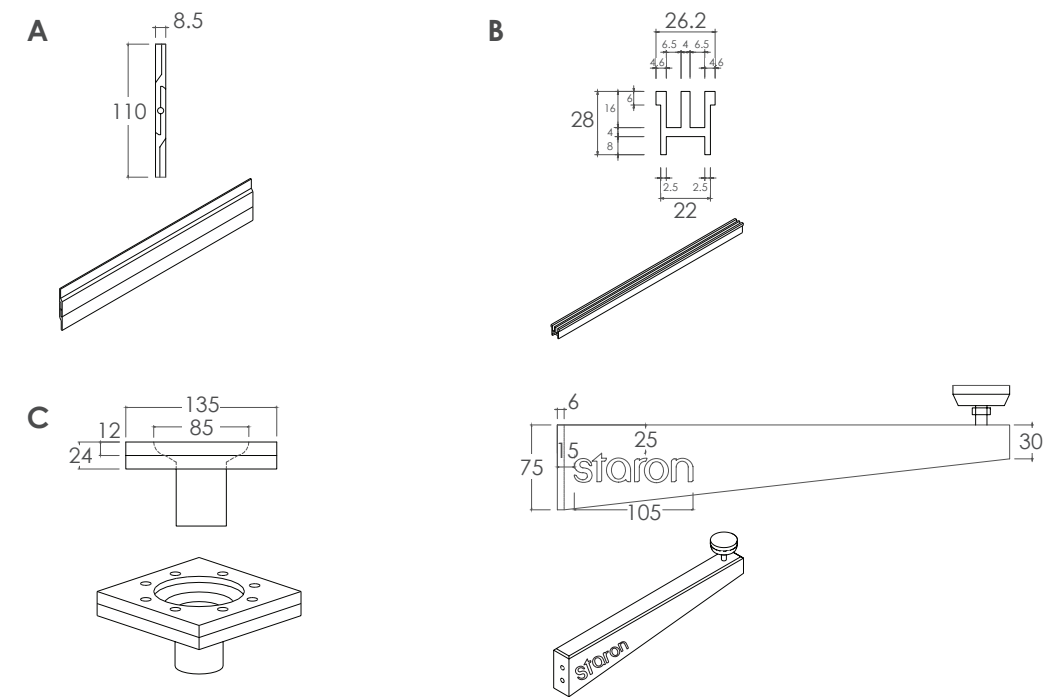

- A** STAINLESS STEEL SPLIT BATTEN - For securing washplane to wall
- B** ALUMINIUM GRATE - Aids easy cleaning & prevents jewellery loss
- C** WASTE OUTLET ASSEMBLY - Simple disassembly allows plumbing access
- D** STAINLESS STEEL BRACKET - Each bracket provides 100kg support



TITLE STARON GRADIENT AIR 5P WITH PARCEL SHELF
 SOLID SURFACE WASHPLANE - FLEXIBLE DIMENSIONS
 COMPATIBLE WITH WALL MOUNT DYSON AIRBLADE
DWG NO. STARON EXAMPLE - 004

DRAWN IV
DATE 01.04.20
CHK'D AS

DO NOT SCALE DRAWING
 SHEET 2 OF 2
 A3

DESIGN REMAINS PROPERTY OF AUSTARON SURFACES AND CAN ONLY BE USED WHEN SPECIFYING STARON SOLID SURFACE.
 Architect to determine design suitability.
 Contact your Staron representative for any colour samples or technical information.

AUS: 17/30 Heathcote Rd Moorebank NSW 2170
NZ: 94 Nevay Rd, Karaka Bays Wellington 6620
 phone: 02 9822 7055
 email: sales@austaron.com.au
 web: austaron.com.au

