

PLAN 3P SCALE 1:10 A3

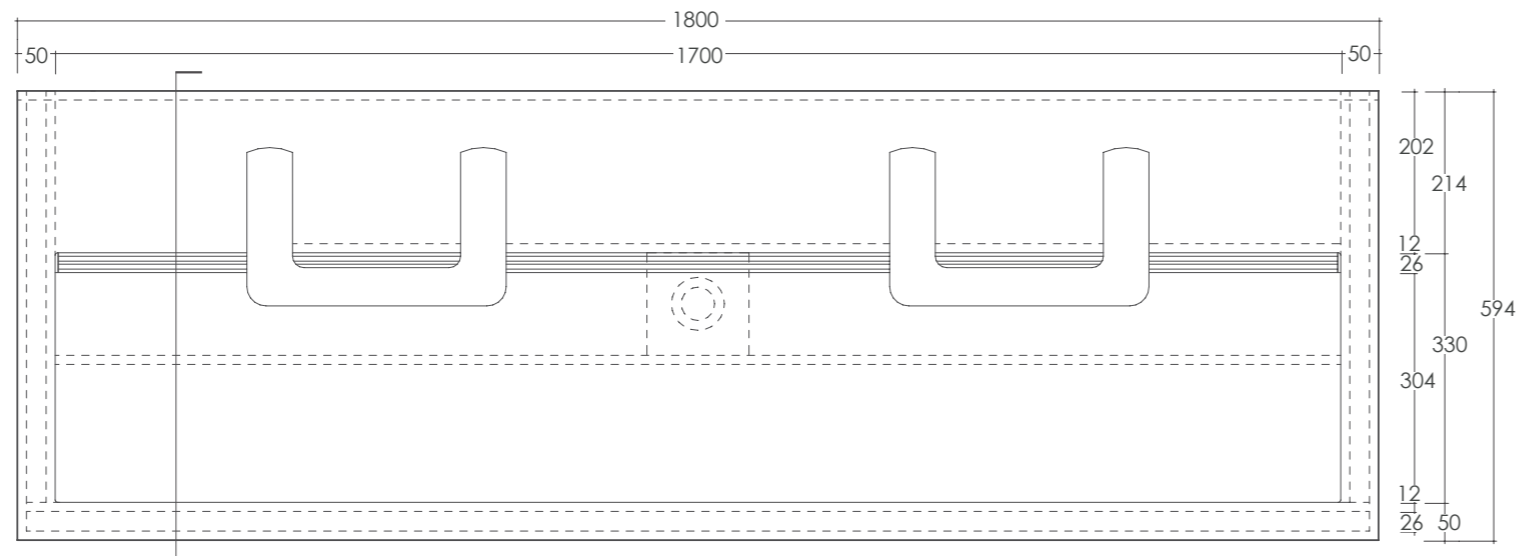

PLAN 2P SCALE 1:10 A3

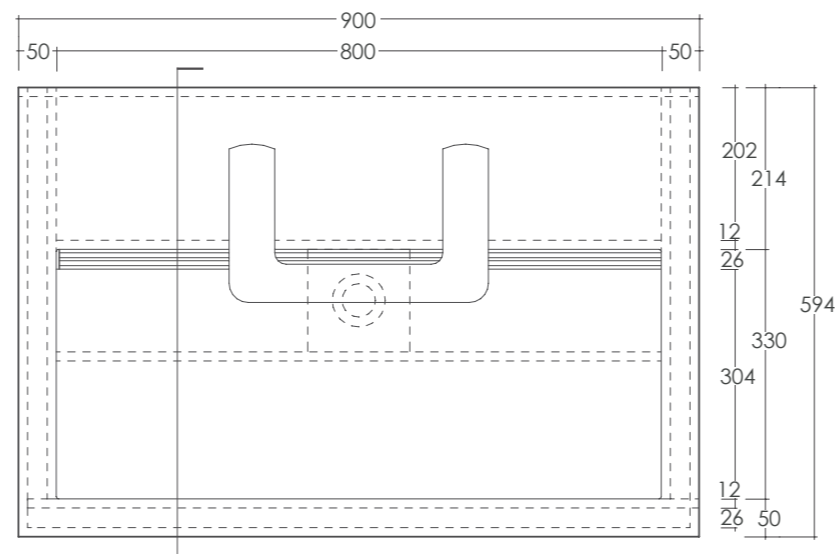

PLAN 1P SCALE 1:10 A3



BRADLEY: WashBar WB1

SPECIFICATION DETAILS

- Australian designed
- Fabricated in every state
- STARON:
 - 2/3 natural mineral and 1/3 acrylic
 - Silica and polyester FREE
 - Greenguard & Greenguard Gold certified
 - 10 Year Warranty
- Unit available in all Staron colours, including mixed combinations
- Aluminium grate supplied in:
 - satin silver grey
 - satin black
 - mill finish (allowing further custom anodising/powder coating)
- All dimensions flexible
- Adapt design to suit joinery units
- Modify form to accommodate:
 - disability rails
 - parcel shelves
 - towel/soap dispensers



AUS: 17/30 Heathcote Rd Moorebank NSW 2170
 NZ: 94 Nevay Rd, Karaka Bays Wellington 6620
 phone: 02 9822 7055
 email: sales@austaron.com.au
 web: austaron.com.au

TITLE **STARON GRADIENT BRADLEY WB1**

SOLID SURFACE WASHPLANE - FLEXIBLE DIMENSIONS
 COMPATIBLE WITH BRADLEY WASHBAR WB1

DWG NO. STARON EXAMPLE - 007

DRAWN SG

DATE 01.10.21

CHK'D AS

DO NOT SCALE DRAWING

SHEET 1 OF 2

A3

DESIGN REMAINS PROPERTY OF AUSTARON SURFACES AND CAN ONLY BE USED WHEN SPECIFYING STARON SOLID SURFACE.

Architect to determine design suitability.
 Contact your Staron representative for any colour samples or technical information.



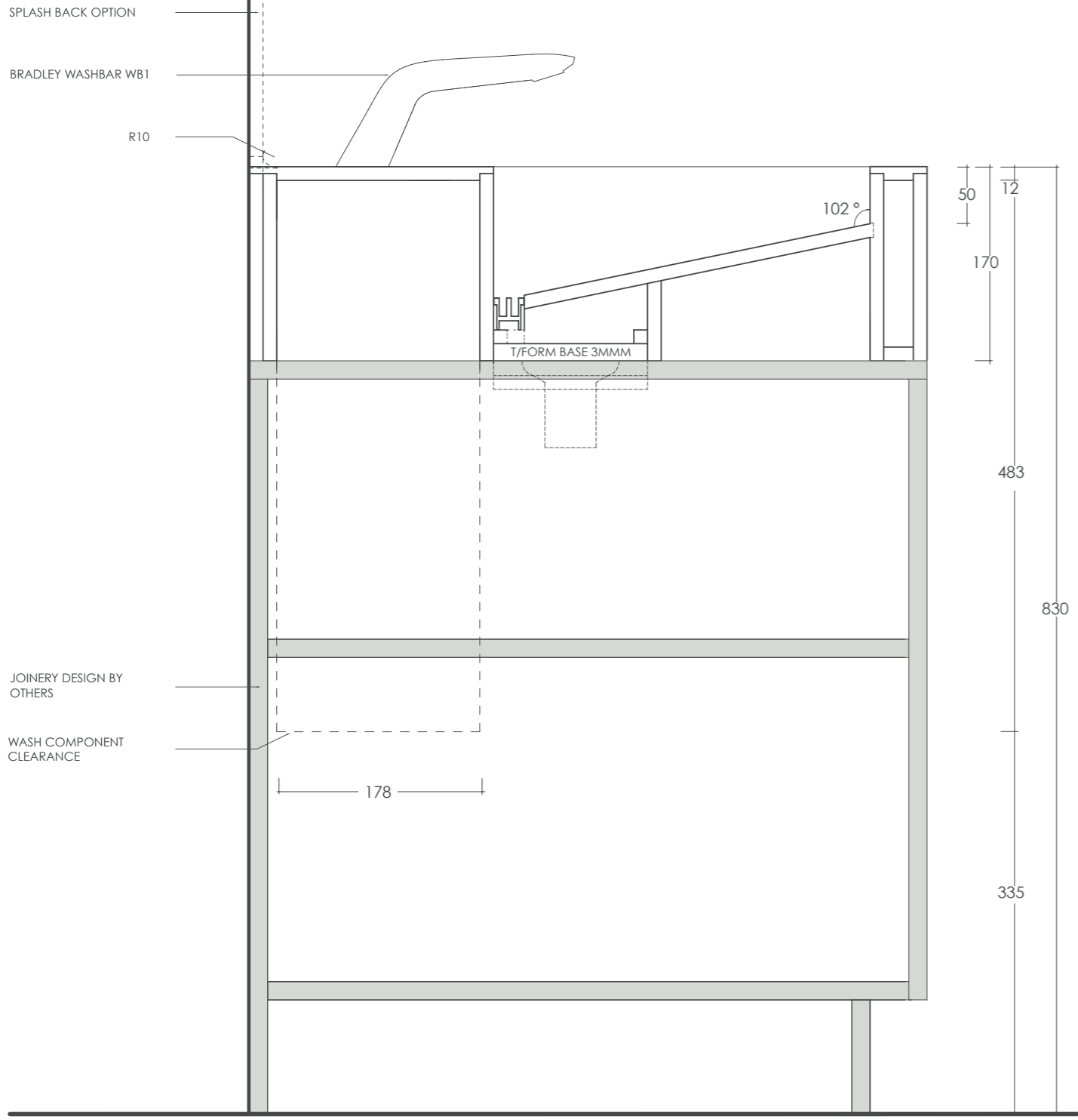
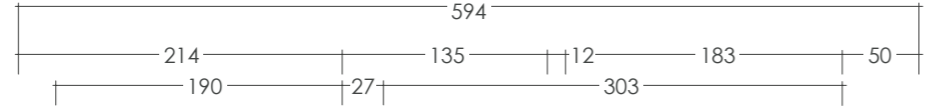

STARON SUPPLIED COMPONENTS

Components only available for use with Staron designs.

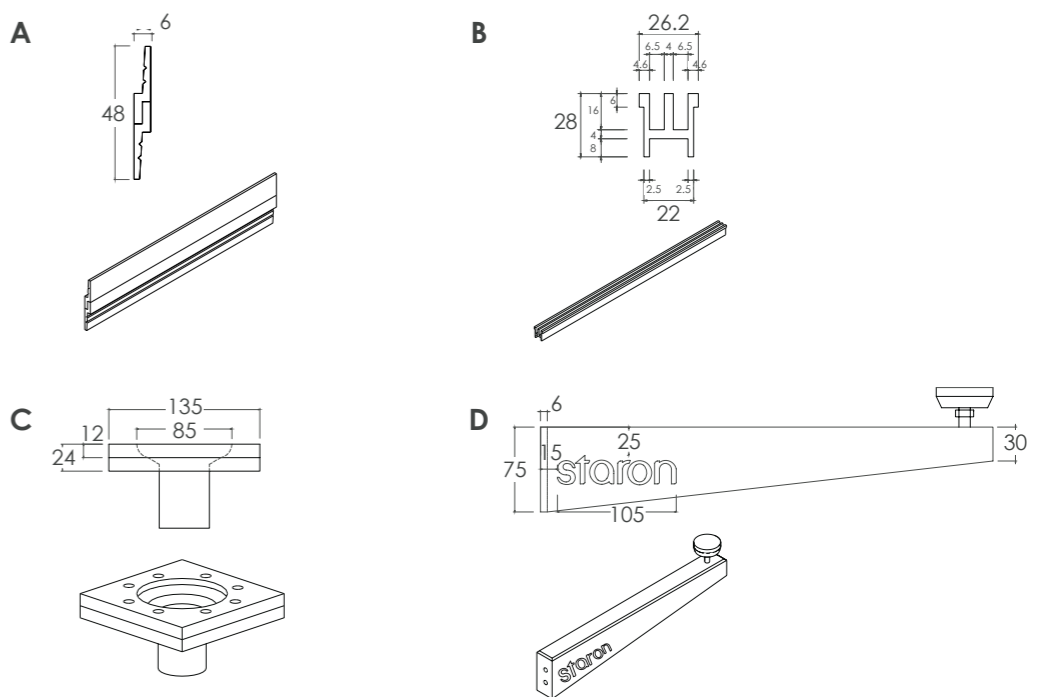

- A** STAINLESS STEEL SPLIT BATTEN - For securing washplane to wall
- B** ALUMINIUM GRATE - Aids easy cleaning & prevents jewellery loss
- C** WASTE OUTLET ASSEMBLY - Simple disassembly allows plumbing access
- D** STAINLESS STEEL BRACKET - Each bracket provides 100kg support

*washplane designed to sit on top of joinery, with the addition of components **A & D** able to accommodate a wall mounted solution

FABRICATION AND INSTALLATION

- Manufacture as per fabrication requirements
- Recommended 1 waste outlet for every 2 taps
- Weight of unit approx. 36kg per lineal metre
- Builder to ensure suitable wall strength to support

SECTION SCALE 1:5 A3



TITLE STARON GRADIENT BRADLEY WB1
SOLID SURFACE WASHPLANE - FLEXIBLE DIMENSIONS
COMPATIBLE WITH BRADLEY WASHBAR WB1

DRAWN SG

DO NOT SCALE DRAWING

DATE 01.10.21

SHEET 2 OF 2

CHK'D AS

A3

DWG NO. STARON EXAMPLE - 007

AUS: 17/30 Heathcote Rd Moorebank NSW 2170
NZ: 94 Nevay Rd, Karaka Bays Wellington 6620
phone: 02 9822 7055
email: sales@austaron.com.au
web: austaron.com.au



DESIGN REMAINS PROPERTY OF AUSTARON SURFACES AND CAN ONLY BE USED WHEN SPECIFYING STARON SOLID SURFACE.

Architect to determine design suitability.
Contact your Staron representative for any colour samples or technical information.