

PLAN SCALE 1:10 A3

**STARON SUPPLIED COMPONENTS**

Components only available for use with Staron designs.

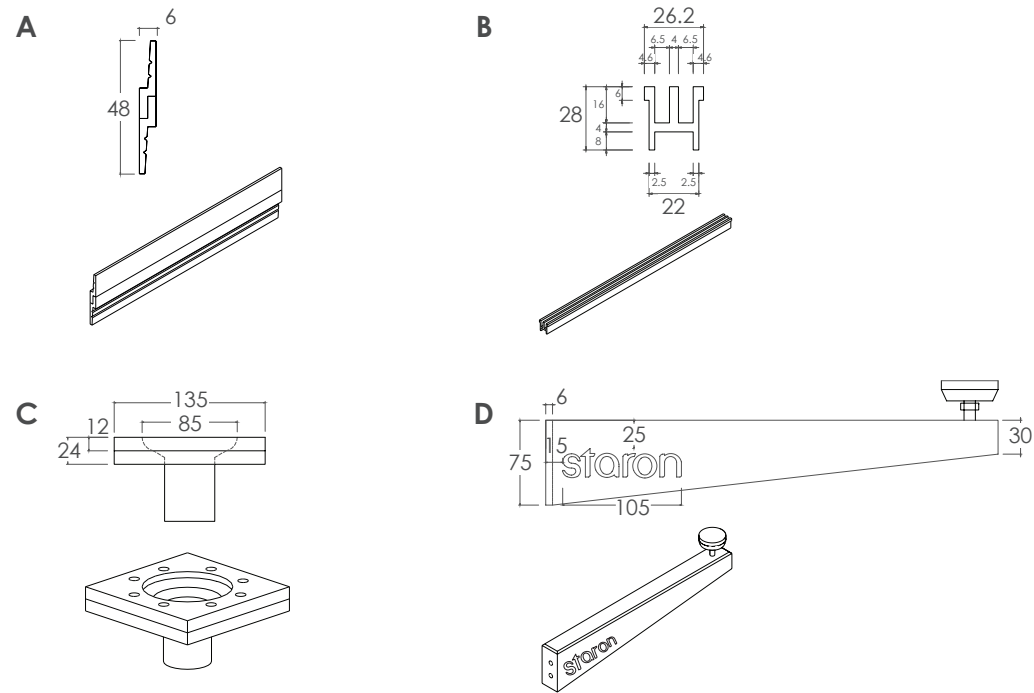

- A** STAINLESS STEEL SPLIT BATTEN - For securing washplane to wall
- B** ALUMINIUM GRATE - Aids easy cleaning & prevents jewellery loss
- C** WASTE OUTLET ASSEMBLY - Simple disassembly allows plumbing access
- D** STAINLESS STEEL BRACKET - Each bracket provides 100kg support

**FABRICATION AND INSTALLATION**

- Manufacture as per fabrication requirements
- Recommended 1 waste outlet for every 2 taps
- Weight of unit approx. 40kg per lineal metre
- Builder to ensure suitable wall strength to support



COLOUR: Staron Supreme Dawn

**SPECIFICATION DETAILS**

- Australian designed
- Fabricated in every state
- STARON:
  - 2/3 natural mineral and 1/3 acrylic
  - Silica and polyester FREE
  - Greenguard & Greenguard Gold certified
  - 10 Year Warranty
- Unit available in all Staron colours, including mixed combinations
- Aluminium grate supplied in:
  - satin silver grey
  - satin black
  - mill finish (allowing further custom anodising/powder coating)
- All dimensions flexible
- Adapt design to suit joinery units
- Modify form to accommodate:
  - disability rails
  - parcel shelves
  - towel/soap dispensers

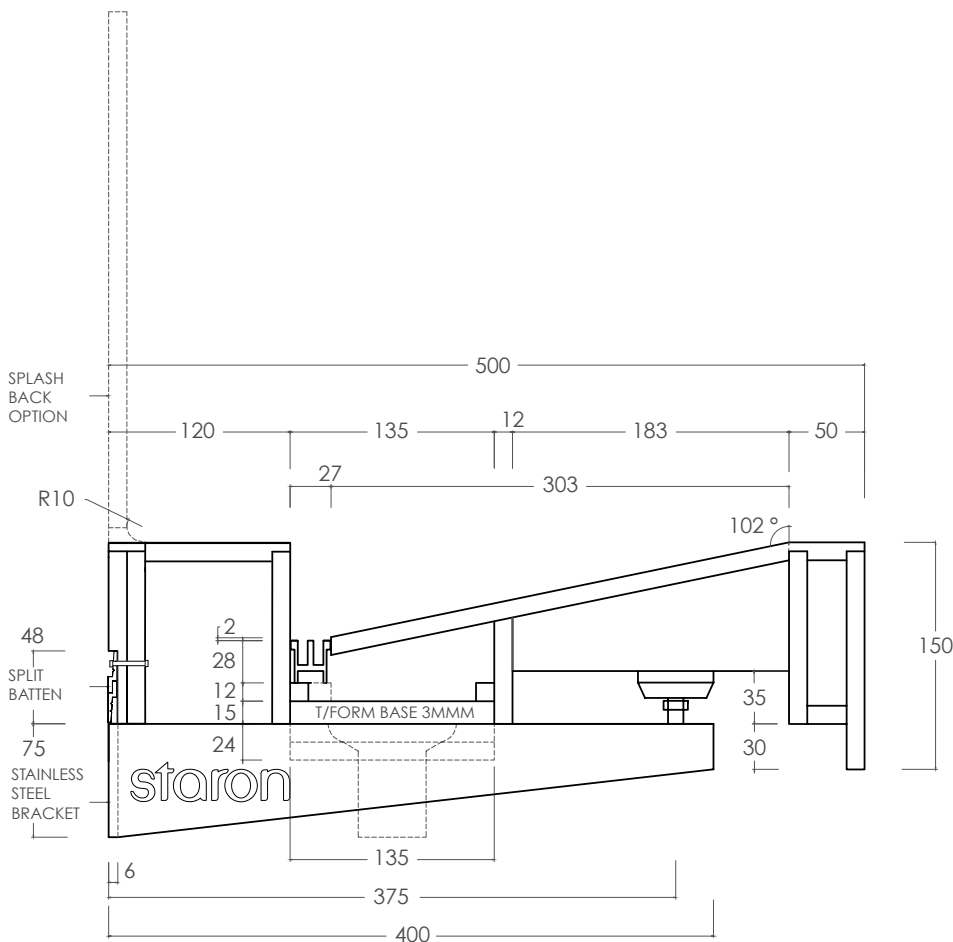

SECTION SCALE 1:5 A3



AUS: 17/30 Heathcote Rd Moorebank NSW 2170  
 NZ: 94 Nevay Rd, Karaka Bays Wellington 6620  
 phone: 02 9822 7055  
 email: sales@austaron.com.au  
 web: austaron.com.au



TITLE **STARON GRADIENT 2P**  
 SOLID SURFACE WASHPLANE - FLEXIBLE DIMENSIONS

DWG NO. STARON EXAMPLE - 001

DRAWN	IV	DO NOT SCALE DRAWING
DATE	01.01.20	SHEET 4 OF 5
CHK'D	AS	A3

**DESIGN REMAINS PROPERTY OF AUSTARON SURFACES AND CAN ONLY BE USED WHEN SPECIFYING STARON SOLID SURFACE.**

Architect to determine design suitability.  
 Contact your Staron representative for any colour samples or technical information.