

PLAN SCALE 1:10 A3

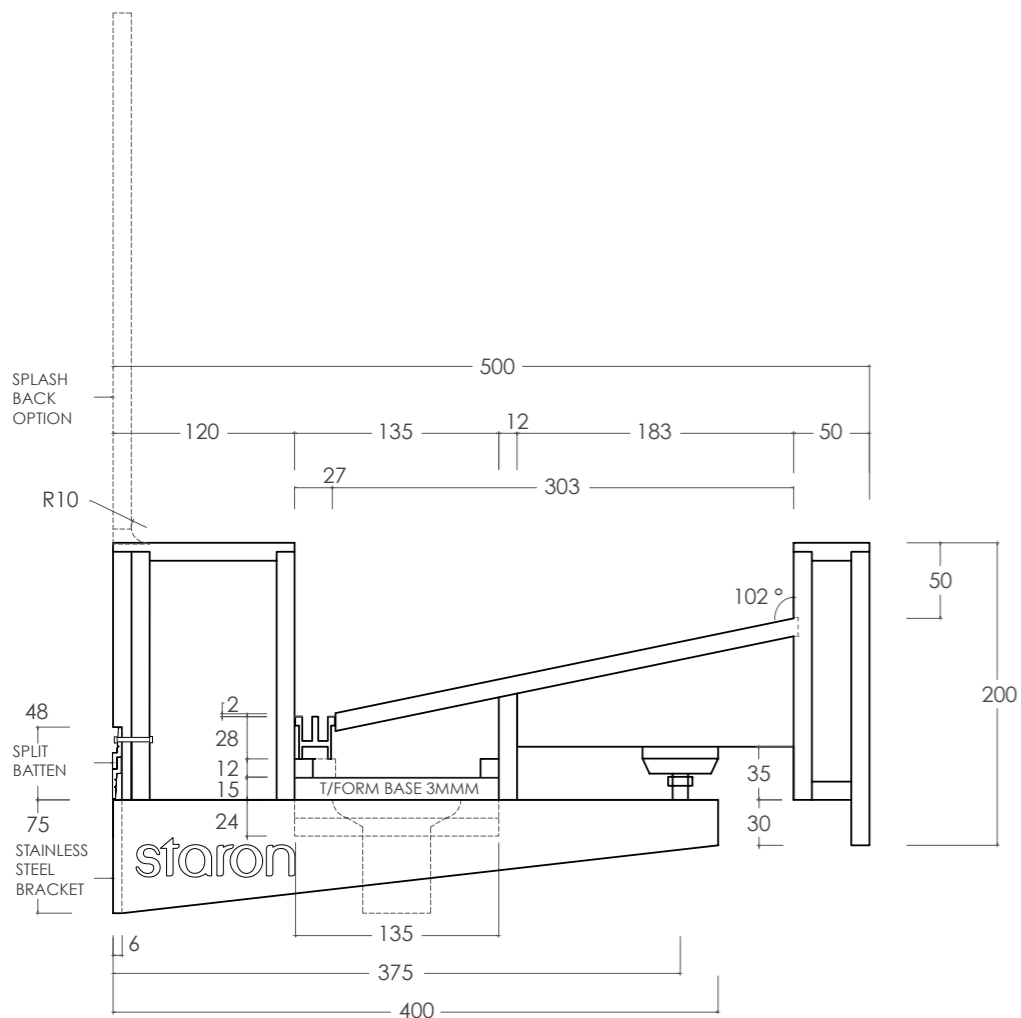

SECTION SCALE 1:5 A3

**STARON SUPPLIED COMPONENTS**

Components only available for use with Staron designs.

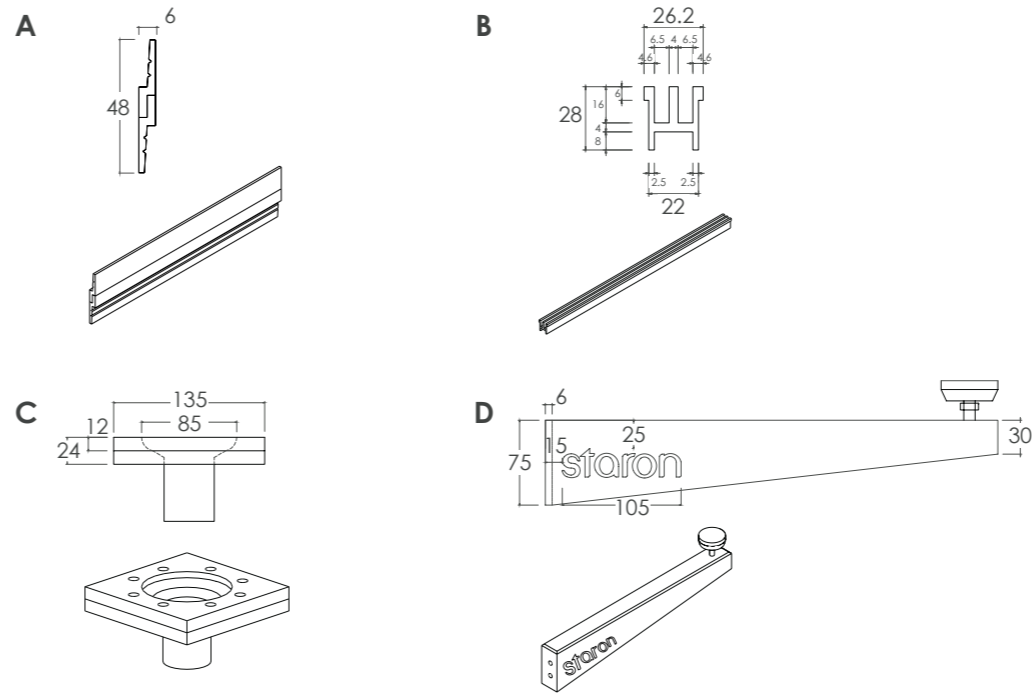

- A** STAINLESS STEEL SPLIT BATTEN - For securing washplane to wall
- B** ALUMINIUM GRATE - Aids easy cleaning & prevents jewellery loss
- C** WASTE OUTLET ASSEMBLY - Simple disassembly allows plumbing access
- D** STAINLESS STEEL BRACKET - Each bracket provides 100kg support

**FABRICATION AND INSTALLATION**

- Manufacture as per fabrication requirements
- Recommended 1 waste outlet for every 2 taps
- Weight of unit approx. 45kg per lineal metre
- Builder to ensure suitable wall strength to support



COLOUR: Staron Bright White and Onyx

**SPECIFICATION DETAILS**

- AUS designed and fabricated in every state STARON:  
2/3 natural mineral and 1/3 acrylic Silica and polyester FREE  
Greenguard & Greenguard Gold certified  
10 Year Warranty
- Unit available in all Staron colours, including mixed combinations
- Aluminium grate supplied in:  
satin silver grey  
satin black  
mill finish (allowing further custom anodising/powder coating)
- All dimensions flexible
- Adapt design to suit joinery units
- Modify form to accommodate:  
disability rails  
parcel shelves  
towel/soap dispensers
- Refine 1712-V & B3192 Dyson compatible, refer to sinks for specification details



AUS: 17/30 Heathcote Rd Moorebank NSW 2170  
 NZ: 94 Nevey Rd, Karaka Bays Wellington 6620  
 phone: 02 9822 7055  
 email: sales@austaron.com.au  
 web: austaron.com.au



TITLE **STARON GRADIENT AIR 1P**

SOLID SURFACE WASHPLANE - FLEXIBLE DIMENSIONS  
 COMPATIBLE WITH DYSON AIRBLADE WD04 & WD06

DWG NO. STARON EXAMPLE - 001

DRAWN IV

DATE 01.01.20

CHK'D AS

DO NOT SCALE DRAWING

SHEET 5 OF 5

A3

**DESIGN REMAINS PROPERTY OF AUSTARON SURFACES AND CAN ONLY BE USED WHEN SPECIFYING STARON SOLID SURFACE.**

Architect to determine design suitability.

Contact your Staron representative for any colour samples or technical information.