

PLAN SCALE 1:10 A3

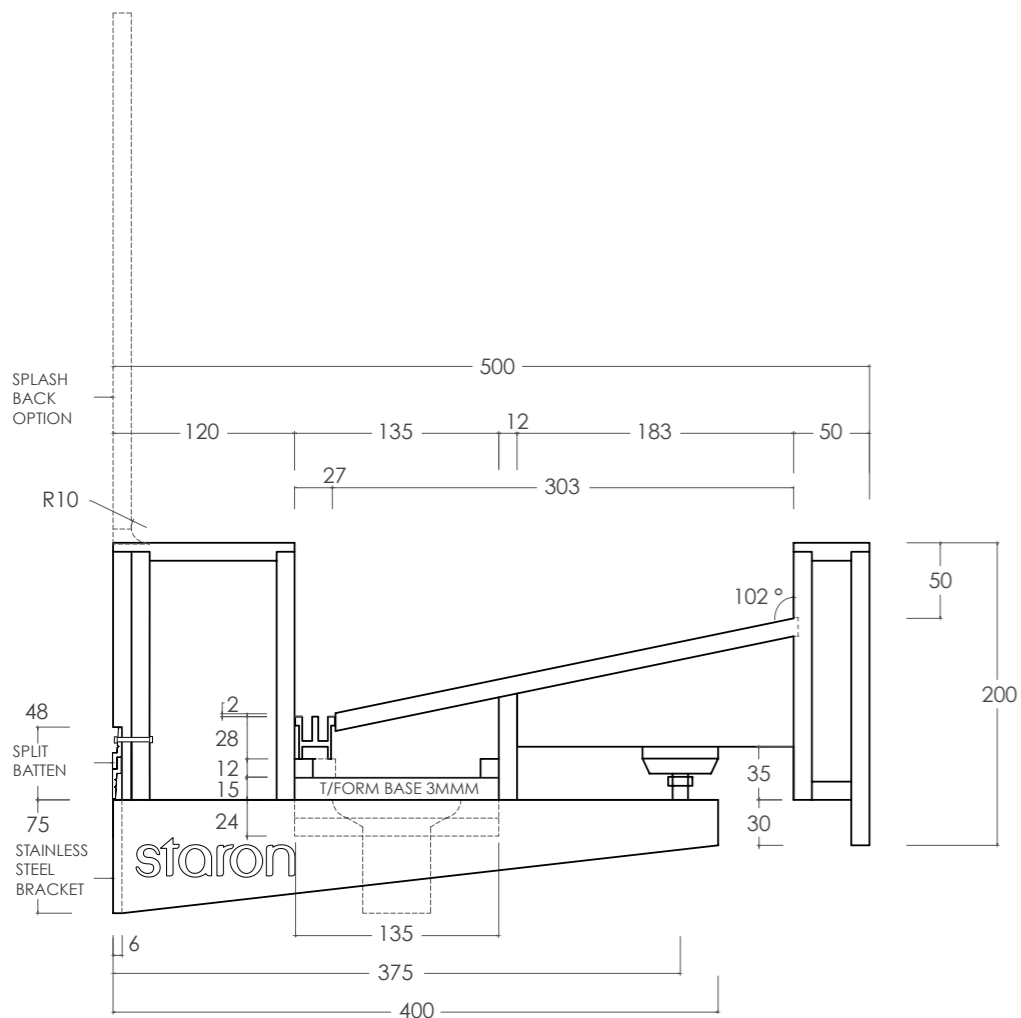

SECTION SCALE 1:5 A3

STARON SUPPLIED COMPONENTS

Components only available for use with Staron designs.

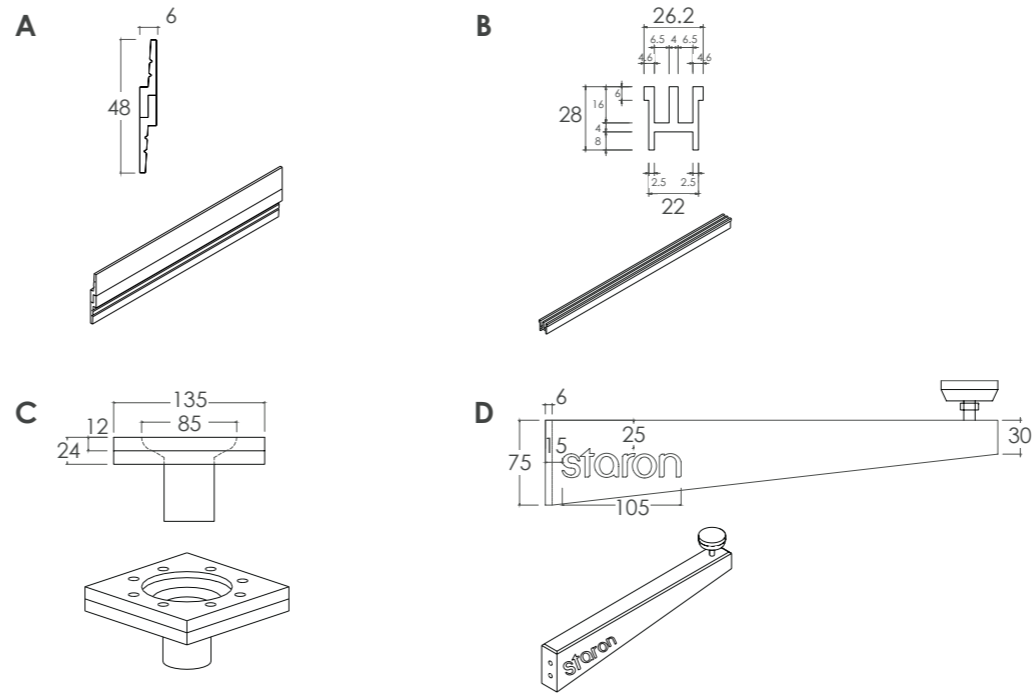

- A** STAINLESS STEEL SPLIT BATTEN - For securing washplane to wall
- B** ALUMINIUM GRATE - Aids easy cleaning & prevents jewellery loss
- C** WASTE OUTLET ASSEMBLY - Simple disassembly allows plumbing access
- D** STAINLESS STEEL BRACKET - Each bracket provides 100kg support

FABRICATION AND INSTALLATION

- Manufacture as per fabrication requirements
- Recommended 1 waste outlet for every 2 taps
- Weight of unit approx. 45kg per lineal metre
- Builder to ensure suitable wall strength to support



COLOUR: Staron Bright White and Onyx

SPECIFICATION DETAILS

- AUS designed and fabricated in every state STARON:
 - 2/3 natural mineral and 1/3 acrylic Silica and polyester FREE
 - Greenguard & Greenguard Gold certified
 - 10 Year Warranty
- Unit available in all Staron colours, including mixed combinations
- Aluminium grate supplied in:
 - satin silver grey
 - satin black
 - mill finish (allowing further custom anodising/powder coating)
- All dimensions flexible
- Adapt design to suit joinery units
- Modify form to accommodate:
 - disability rails
 - parcel shelves
 - towel/soap dispensers
- Refine 1712-V & B3192 Dyson compatible, refer to sinks for specification details



AUS: 17/30 Heathcote Rd Moorebank NSW 2170
 NZ: 94 Nevay Rd, Karaka Bays Wellington 6620
 phone: 02 9822 7055
 email: sales@austaron.com.au
 web: austaron.com.au



TITLE **STARON GRADIENT AIR 4P**

SOLID SURFACE WASHPLANE - FLEXIBLE DIMENSIONS
 COMPATIBLE WITH DYSON AIRBLADE WD04 & WD06

DWG NO. STARON EXAMPLE - 001

DRAWN IV

DO NOT SCALE DRAWING

DATE 01.01.20

SHEET 2 OF 5

CHK'D AS

A3

DESIGN REMAINS PROPERTY OF AUSTARON SURFACES AND CAN ONLY BE USED WHEN SPECIFYING STARON SOLID SURFACE.

Architect to determine design suitability.

Contact your Staron representative for any colour samples or technical information.