

**PLAN SCALE 1:20**

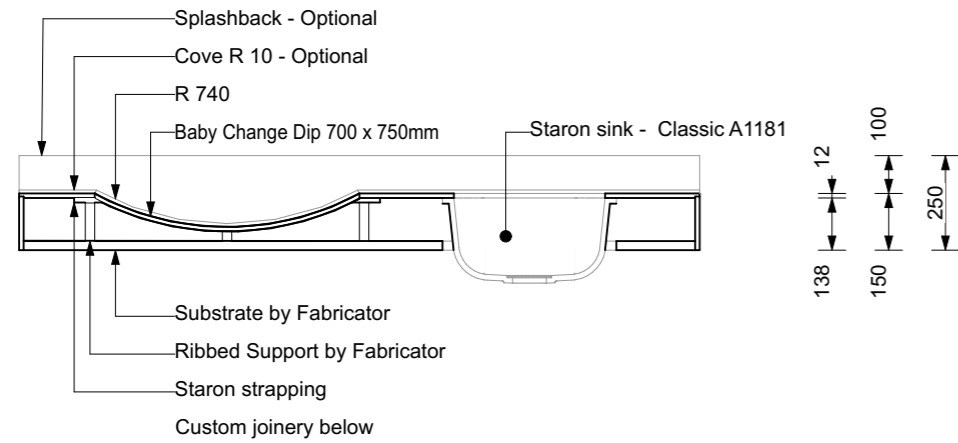

**SECTION A-A 1:20**

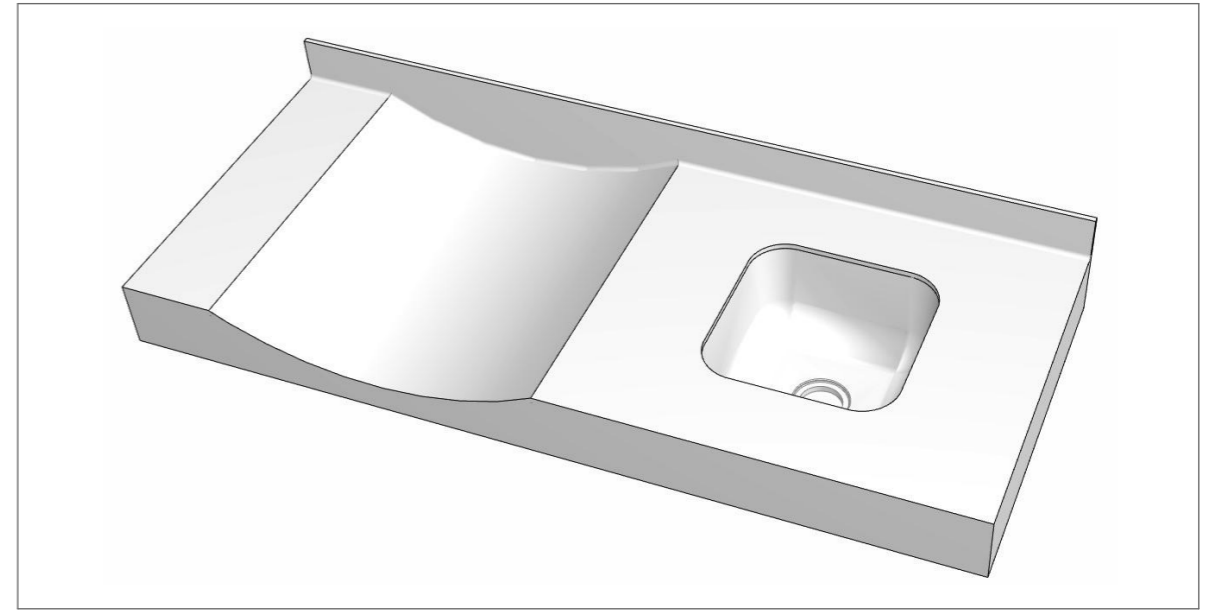
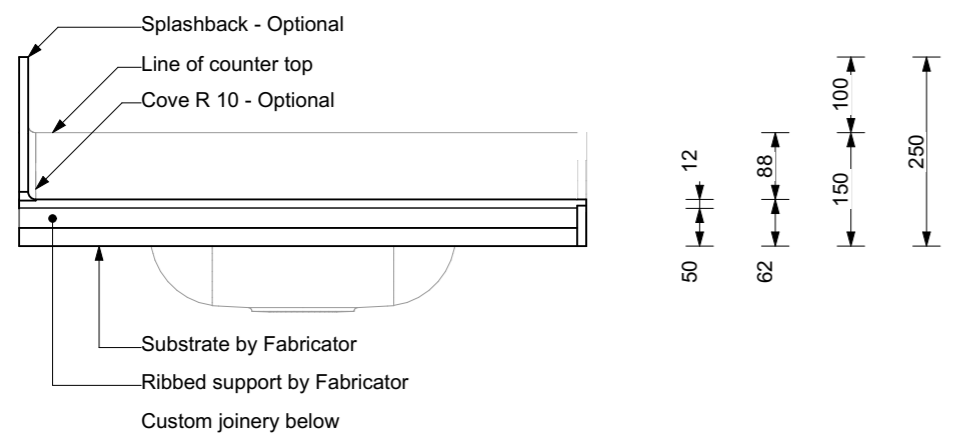

**SECTION B-B 1:10**

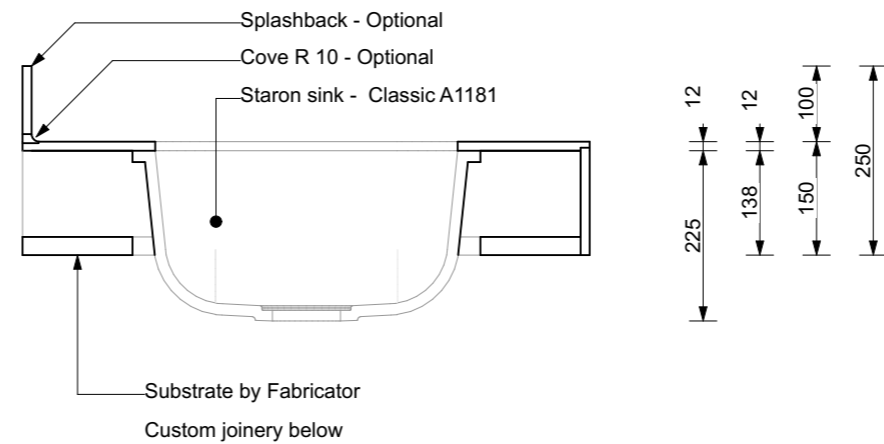

**SECTION C-C 1:10**

**SPECIFICATION DETAILS**

- Australian designed
- Fabricated in every state
- STARON
  - 2/3 natural mineral and 1/3 acrylic
  - Silica and polyester free
  - Greenguard & Greenguard Gold certified
  - 10 Year Warranty
- Unit available in all Staron colours including mixed combinations
- All dimensions flexible
- Height to be confirmed by Architect / Designer

**FABRICATION & INSTALLATION**

- Manufacture as per fabrication requirements
- Weight of unit approx 50kg per lineal metre
- Builder to ensure suitable joinery below to support

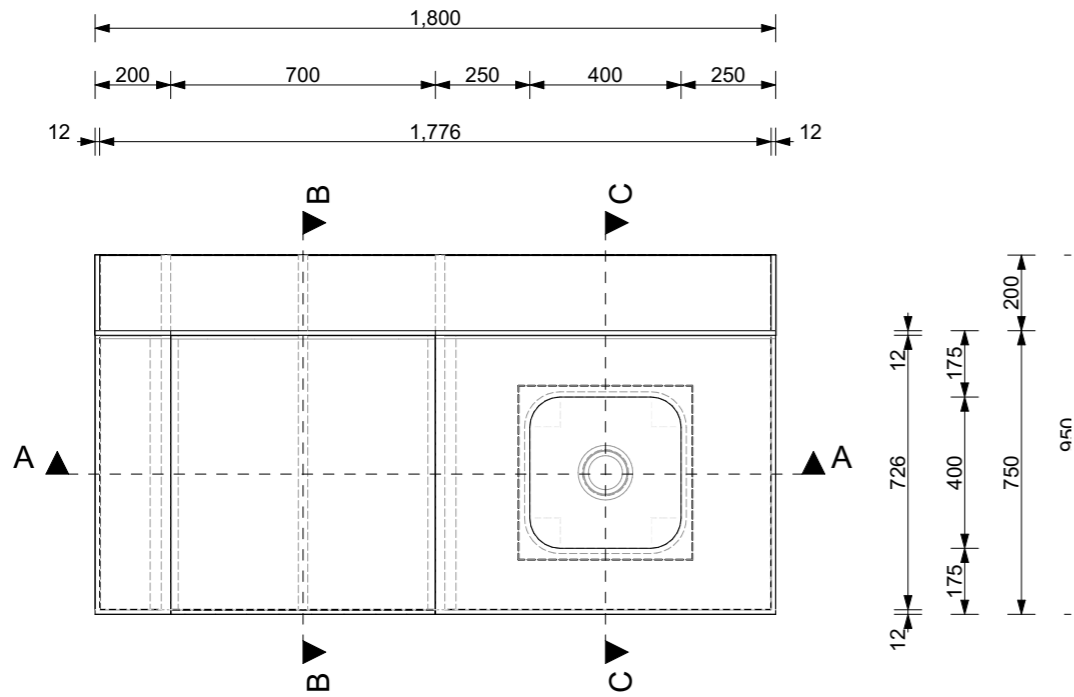

**PLAN SCALE 1:20**

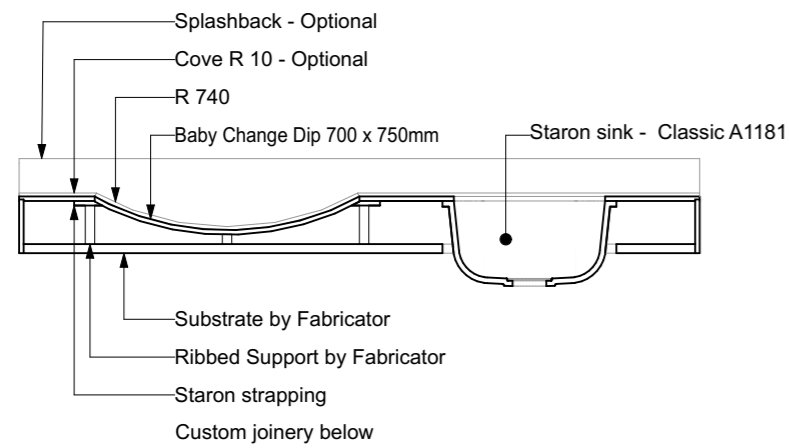
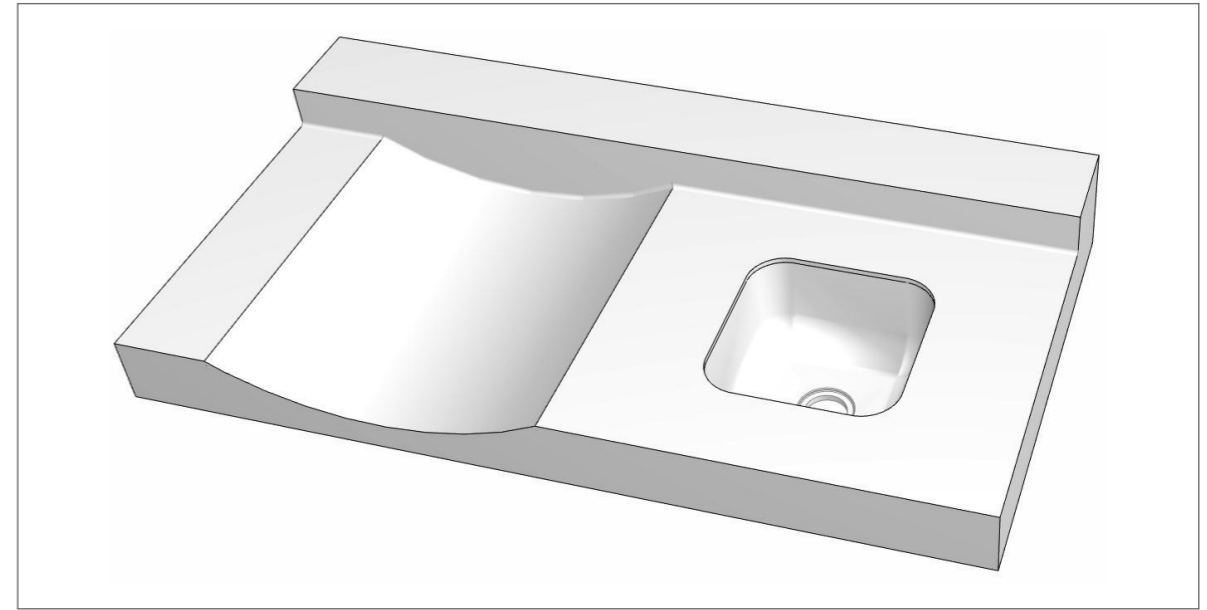

**SECTION A-A 1:20**

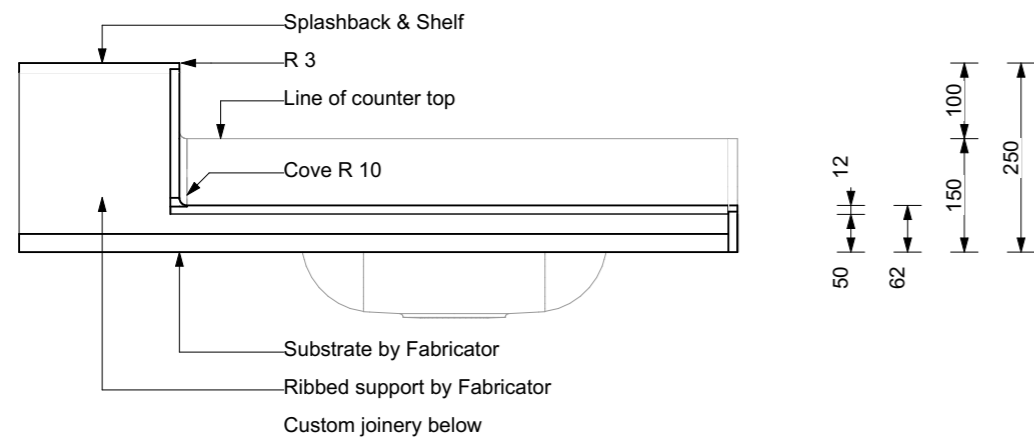

**SECTION B-B 1:10**

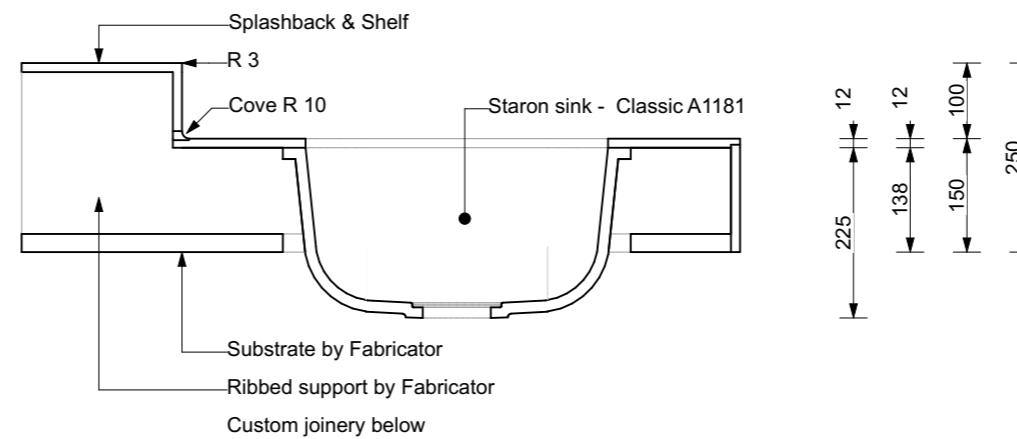

**SECTION C-C 1:10**

**SPECIFICATION DETAILS**

- Australian designed
- Fabricated in every state
- STARON
  - 2/3 natural mineral and 1/3 acrylic
  - Silica and polyester free
  - Greenguard & Greenguard Gold certified
  - 10 Year Warranty
- Unit available in all Staron colours including mixed combinations
- All dimensions flexible
- Height to be confirmed by Architect / Designer

**FABRICATION & INSTALLATION**

- Manufacture as per fabrication requirements
- Weight of unit approx 50kg per lineal metre
- Builder to ensure suitable joinery below to support

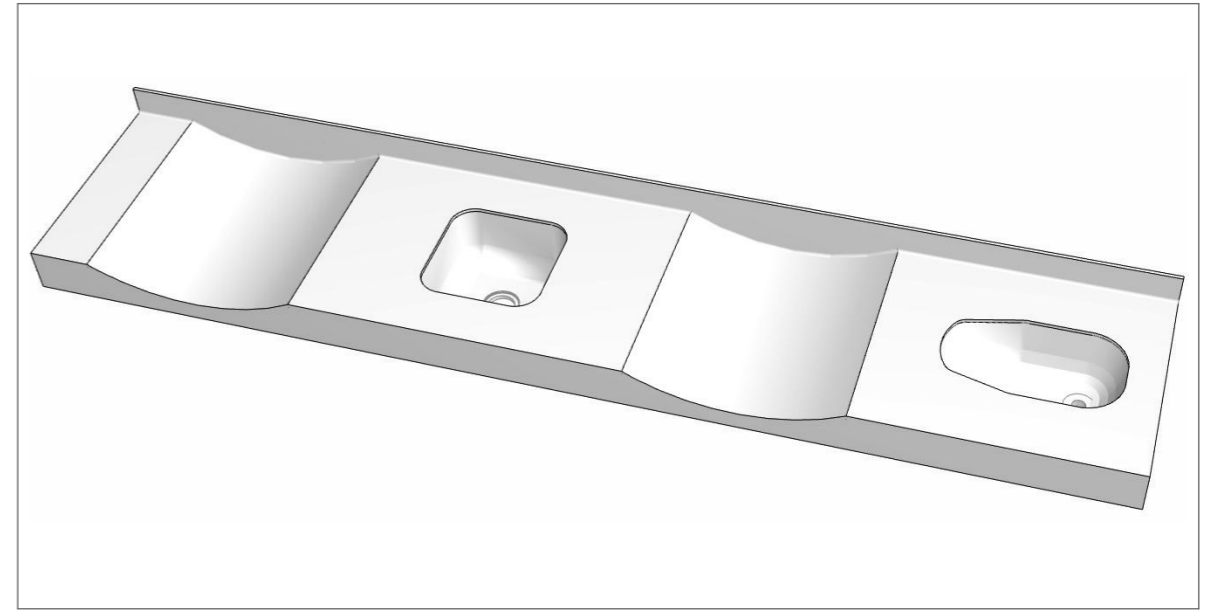
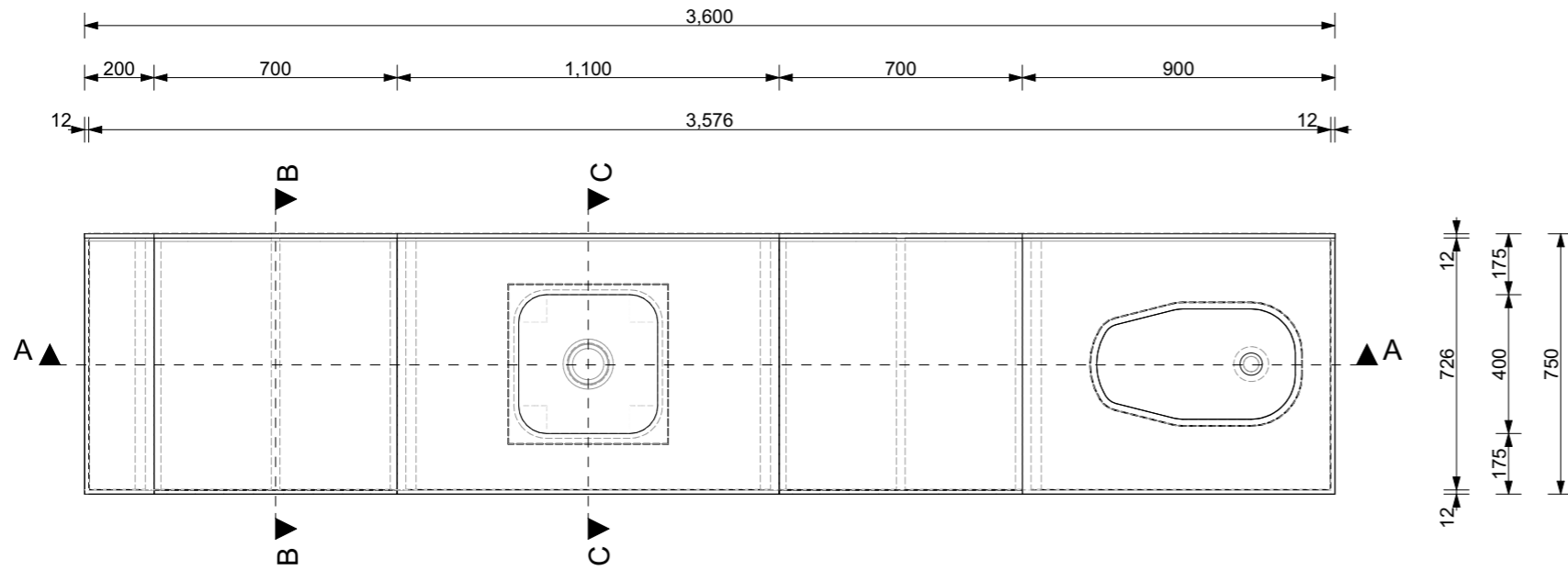

**PLAN SCALE 1:20**

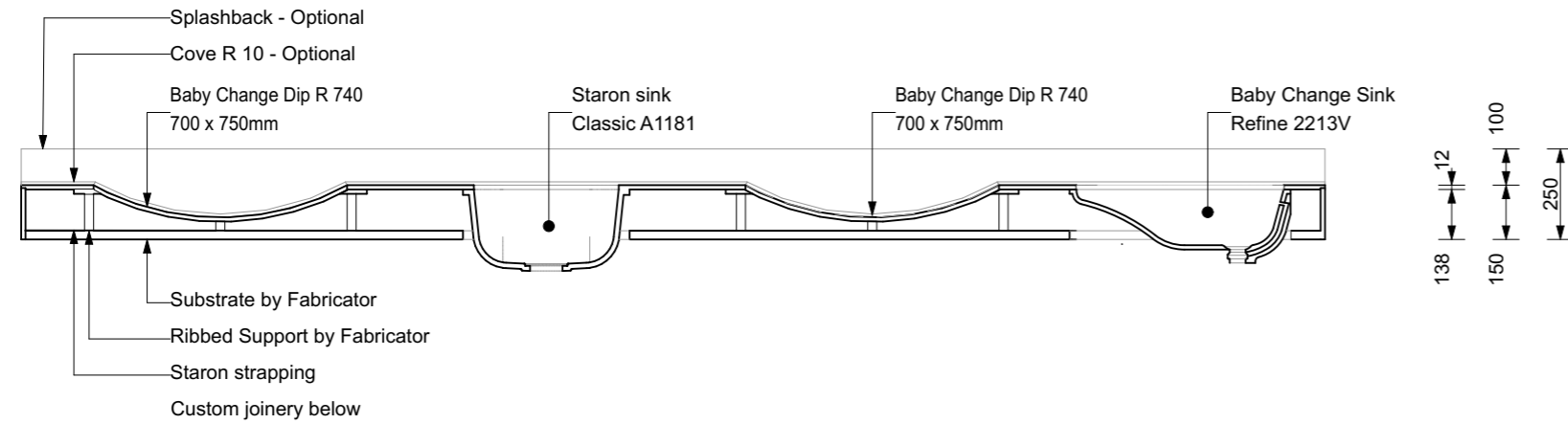

**SECTION A-A 1:20**

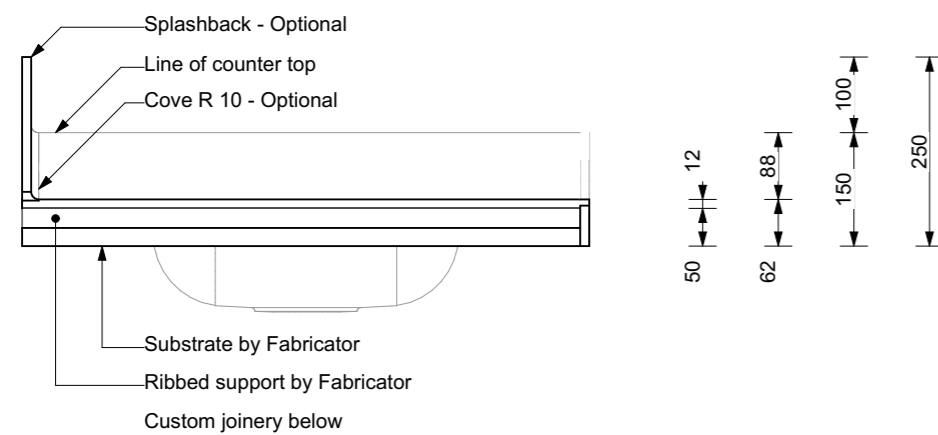

**SECTION B-B 1:10**

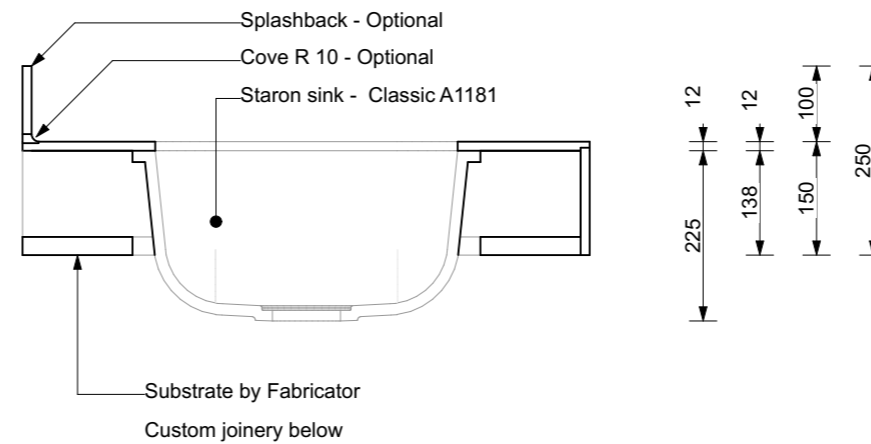

**SECTION C-C 1:10**

**SPECIFICATION DETAILS**

- Australian designed
- Fabricated in every state
- STARON
  - 2/3 natural mineral and 1/3 acrylic
  - Silica and polyester free
  - Greenguard & Greenguard Gold certified
  - 10 Year Warranty
- Unit available in all Staron colours
- including mixed combinations
- All dimensions flexible
- Height to be confirmed by Architect / Designer

**FABRICATION & INSTALLATION**

- Manufacture as per fabrication requirements
- Weight of unit approx 50kg per lineal metre
- Builder to ensure suitable joinery below to support

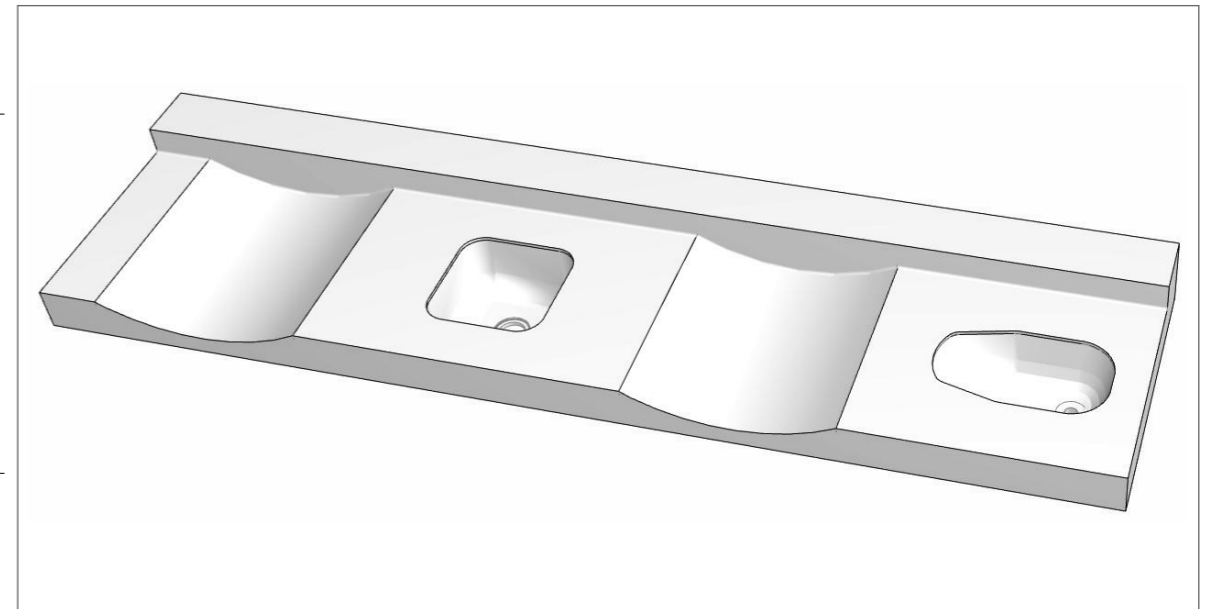
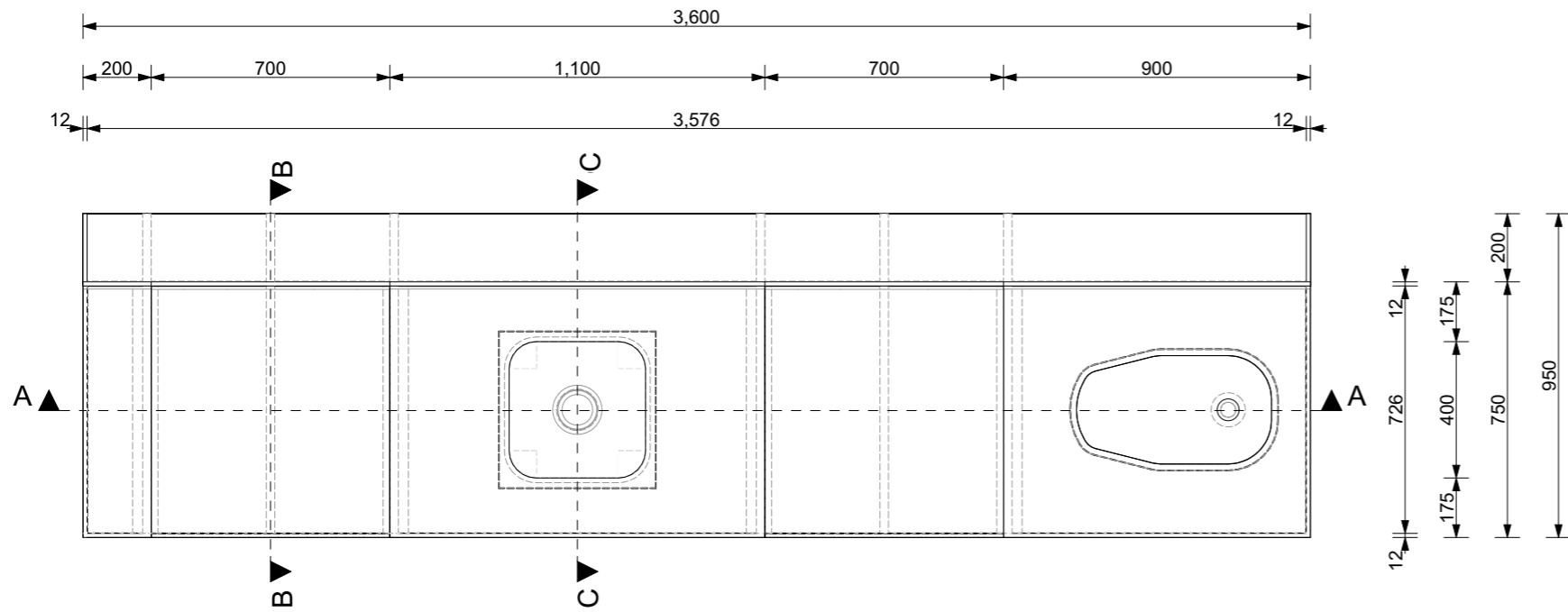

**PLAN SCALE 1:20**

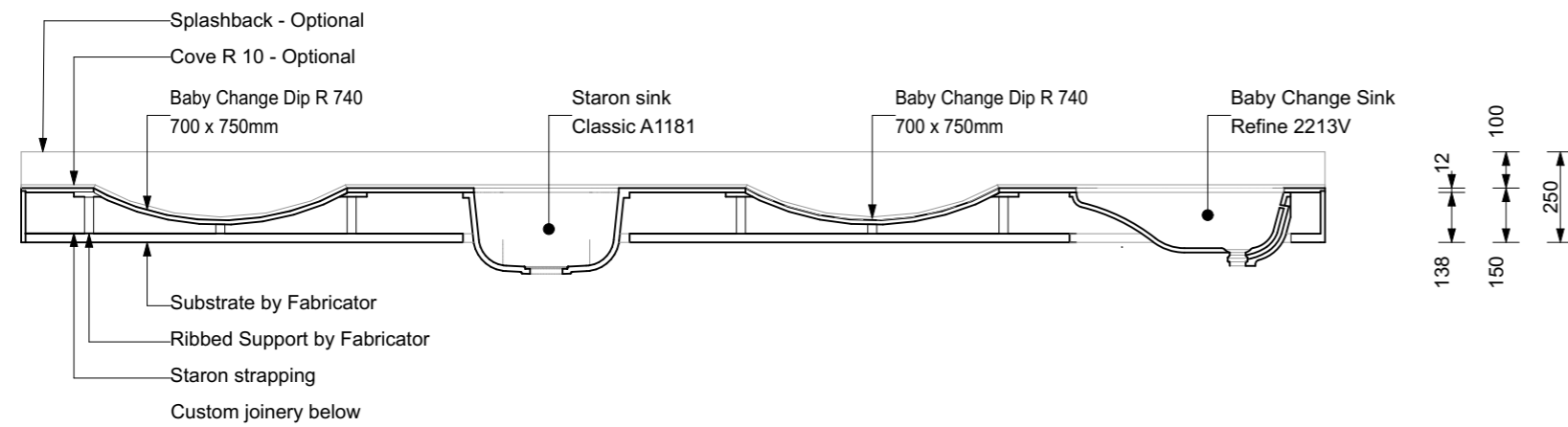

**SECTION A-A 1:20**

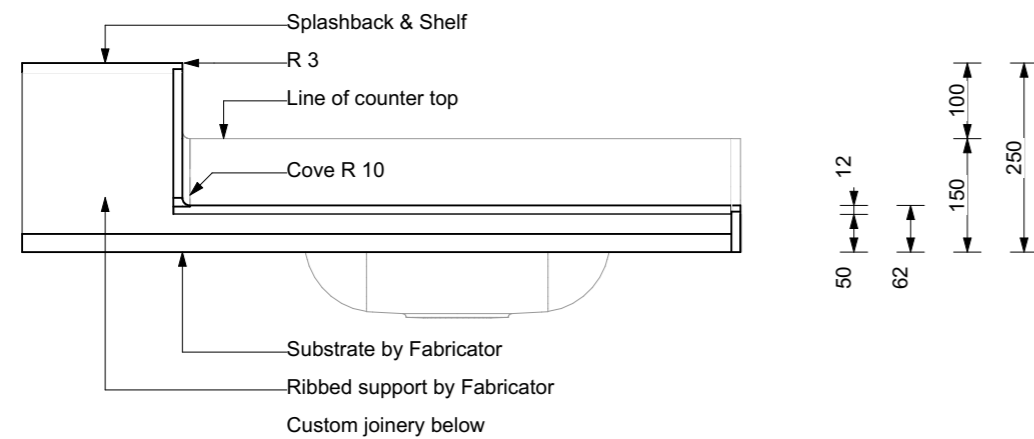

**SECTION B-B 1:10**

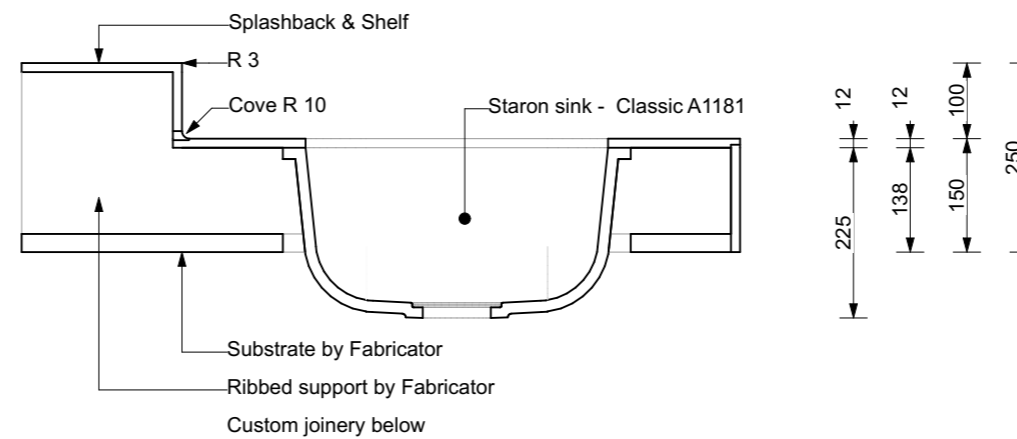

**SECTION C-C 1:10**

**SPECIFICATION DETAILS**

- Australian designed
- Fabricated in every state
- STARON
  - 2/3 natural mineral and 1/3 acrylic
  - Silica and polyester free
  - Greenguard & Greenguard Gold certified
  - 10 Year Warranty
- Unit available in all Staron colours including mixed combinations
- All dimensions flexible
- Height to be confirmed by Architect / Designer

**FABRICATION & INSTALLATION**

- Manufacture as per fabrication requirements
- Weight of unit approx 50kg per lineal metre
- Builder to ensure suitable joinery below to support

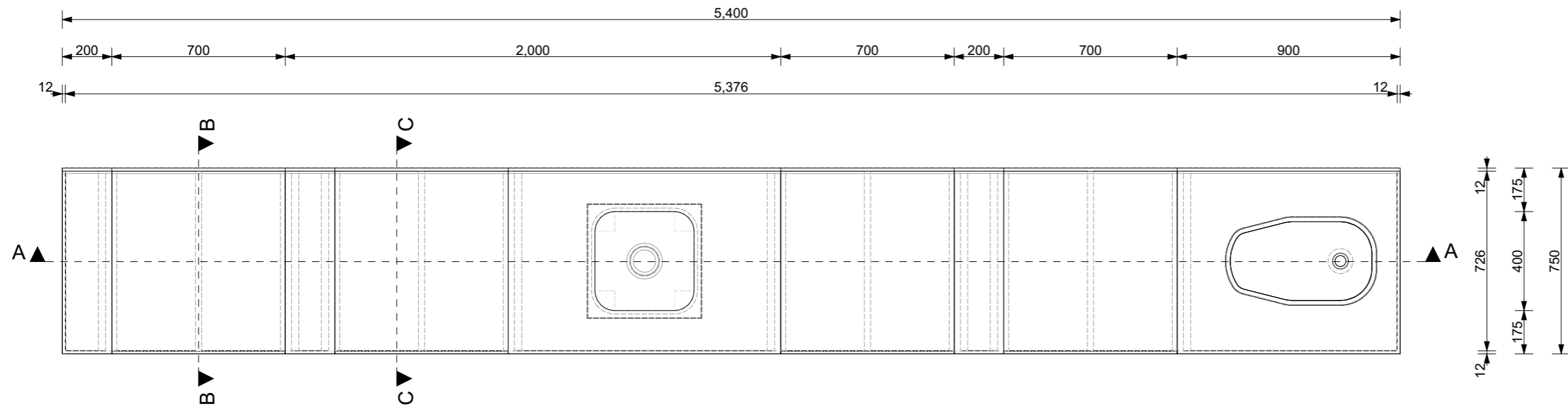

**PLAN SCALE 1:20**

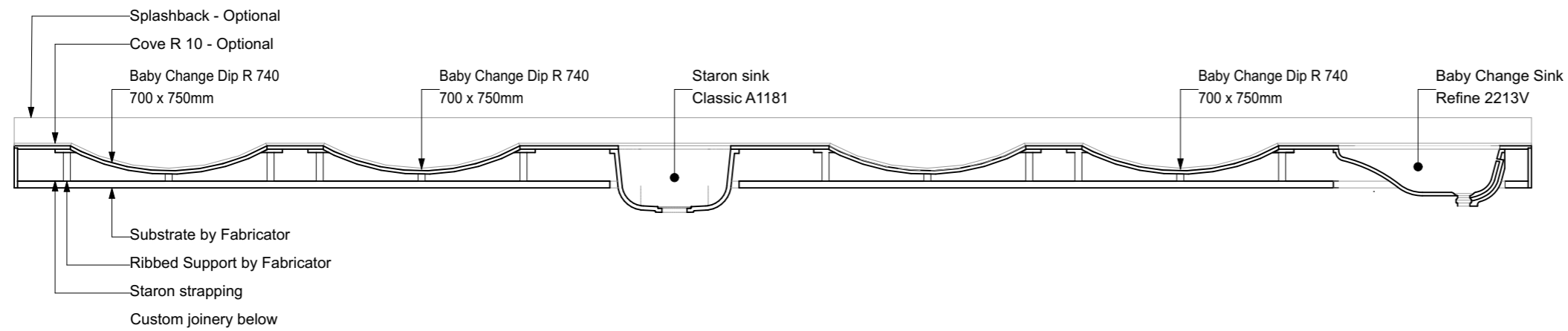

**SECTION A-A 1:20**

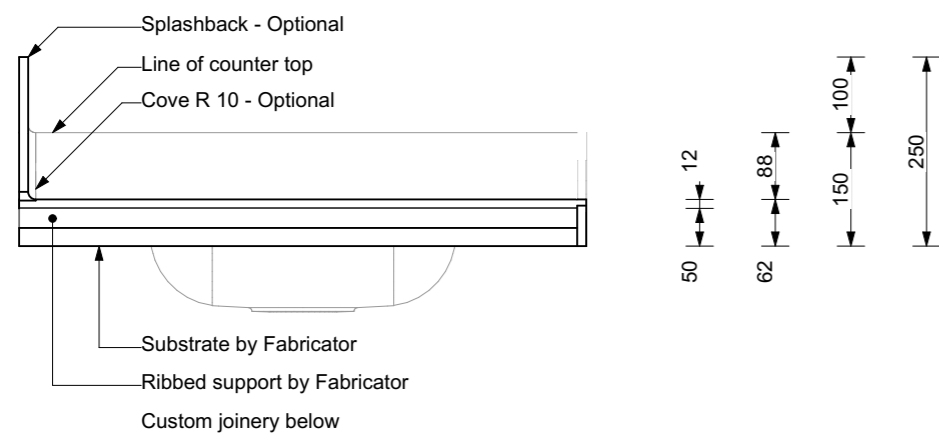

**SECTION B-B 1:10**

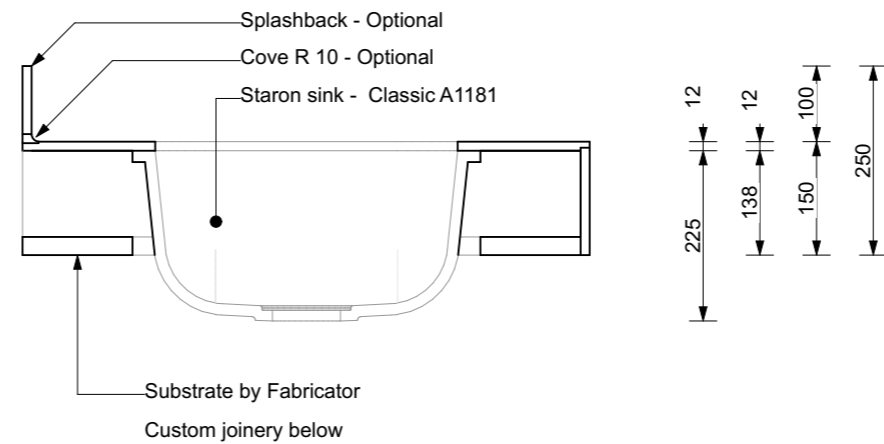

**SECTION C-C 1:10**

**SPECIFICATION DETAILS**

- Australian designed
- Fabricated in every state
- STARON
  - 2/3 natural mineral and 1/3 acrylic
  - Silica and polyester free
  - Greenguard & Greenguard Gold certified
  - 10 Year Warranty
- Unit available in all Staron colours
- including mixed combinations
- All dimensions flexible
- Height to be confirmed by Architect / Designer

**FABRICATION & INSTALLATION**

- Manufacture as per fabrication requirements
- Weight of unit approx 50kg per lineal metre
- Builder to ensure suitable joinery below to support

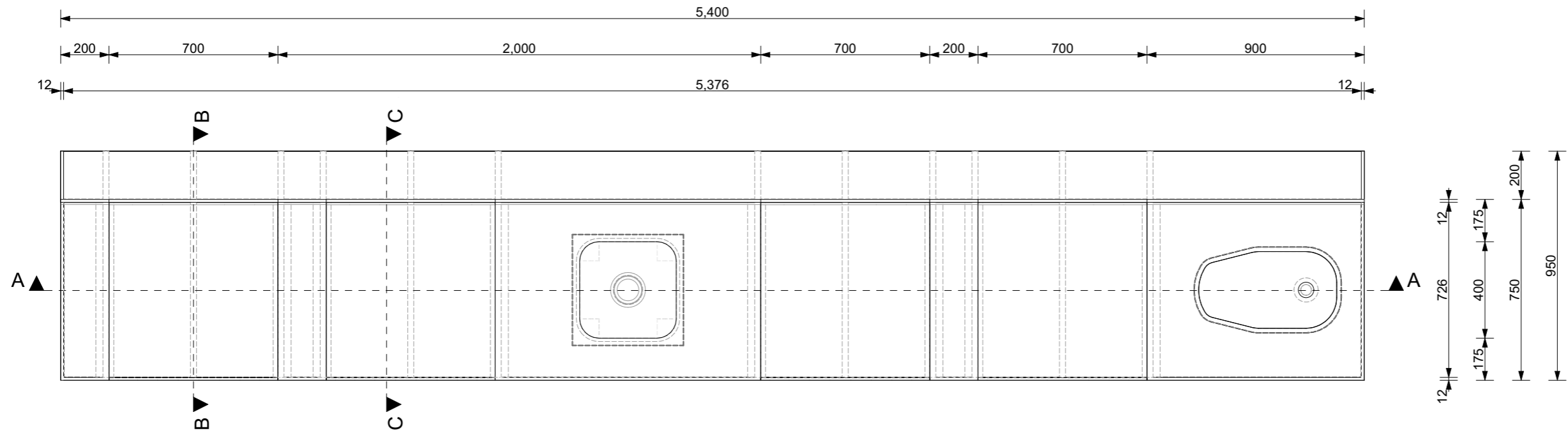

**PLAN SCALE 1:20**

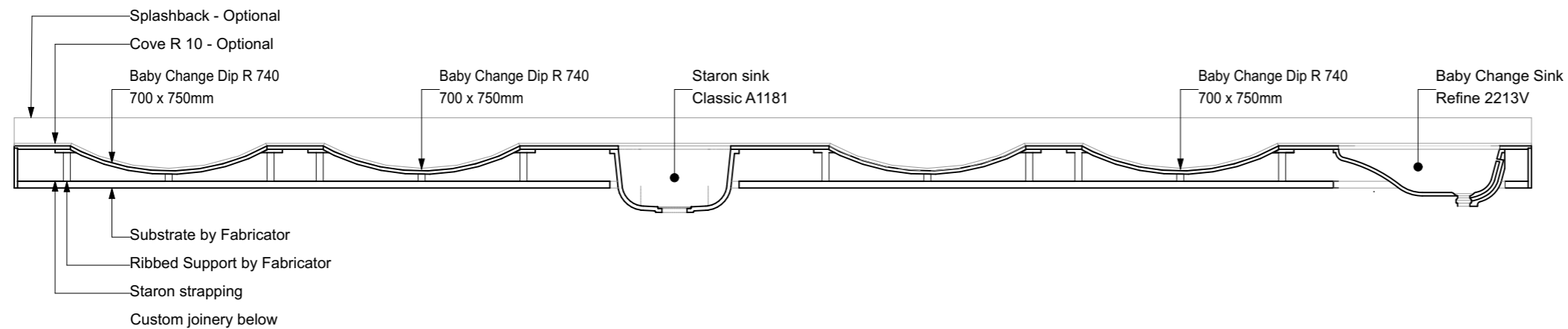

**SECTION A-A 1:20**

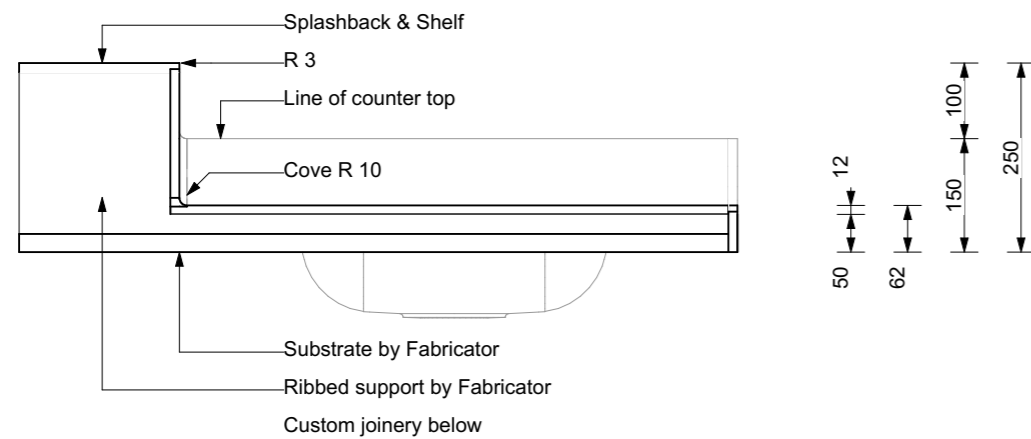

**SECTION B-B 1:10**

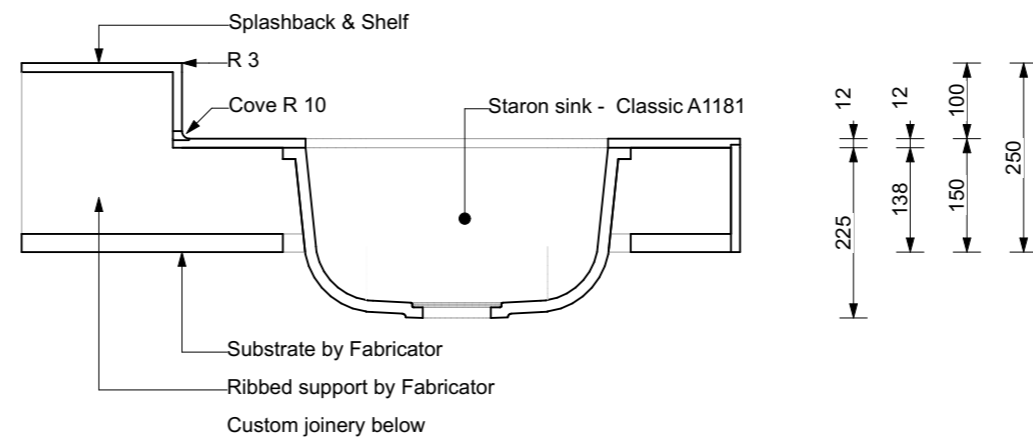

**SECTION C-C 1:10**

**SPECIFICATION DETAILS**

- Australian designed
- Fabricated in every state
- STARON
  - 2/3 natural mineral and 1/3 acrylic
  - Silica and polyester free
  - Greenguard & Greenguard Gold certified
  - 10 Year Warranty
- Unit available in all Staron colours
- including mixed combinations
- All dimensions flexible
- Height to be confirmed by Architect / Designer

**FABRICATION & INSTALLATION**

- Manufacture as per fabrication requirements
- Weight of unit approx 50kg per lineal metre
- Builder to ensure suitable joinery below to support

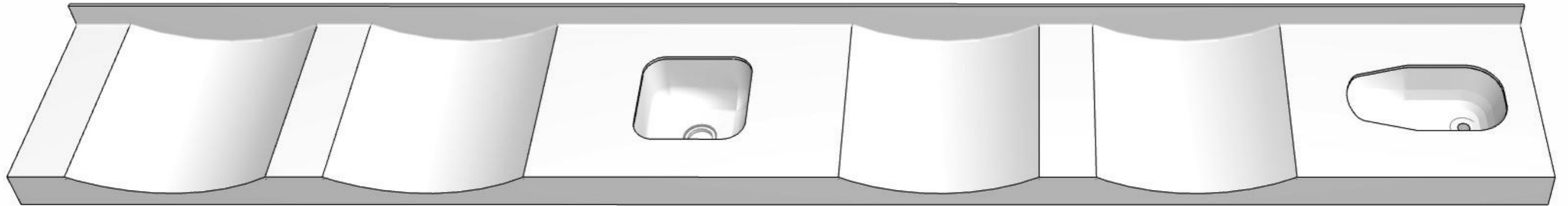

**Staron Baby Change 4**

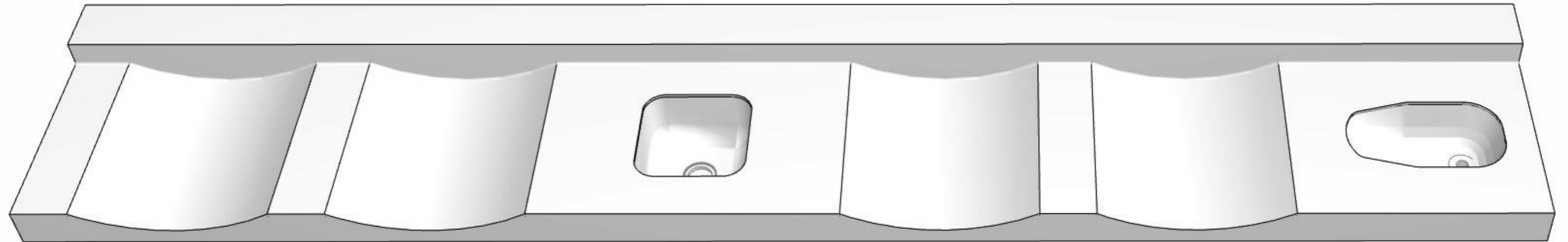

**Staron Baby Change 4 with Shelf**