

Staron® Exterior Wall Cladding

SN-803-2020

1. Features of Staron[®] Exterior Wall

2. Physical Properties

3. Recommended Color for the Exterior

4. Preparation

4.1 Staron[®] Sheet

4.2 Fabrication Equipments

5. Sheet Fabrication

5.1 Polishing

5.2 Thermoforming

5.3 Engraving and Inlay

5.4 Sheet Size and Edge Treatment

5.5 Luminous Application

6. Installation

6.1 Advantages of Ventilated Façade System

6.2 Anchoring System

6.3 Aluminum Frame Substructure

6.4 Fasteners

6.5 Under cut Hole Drilling

6.6 Case study

7. Care and Maintenance

SN-803-2020



It is a light exterior material.

Staron® is easy to handle and has an effect of reducing the overall weight of building as it is relatively lightweight from having low specific gravity compared to stone or glass used in the past. Especially in case of remodeling, it is more advantageous for the safety of building as the finishing material gets lighter.



Structural performance is stable.

It has excellent flexural strength and tensile strength to enable stable installation through the anchor construction.

It is a product with excellent fire resistance.

Staron® is a product approved as Class 1 by going through a surface combustion test (ASTM E84) prescribed by American Society for Testing Materials (ASTM).

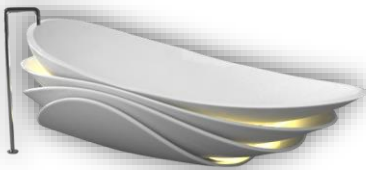

Curved design is possible through thermoforming.

Staron® enables thermoforming as a product that can illustrate the beauty and 3D structure of curve by escaping from a two-dimensional design.



Provides an optimum product for outside usage

Staron® provides optimum color and solution by going through the tests on thermal expansion property according to the change of temperature, accelerated weathering property/free-thaw resistance according to the change of weather and various contaminations according to the surrounding environment

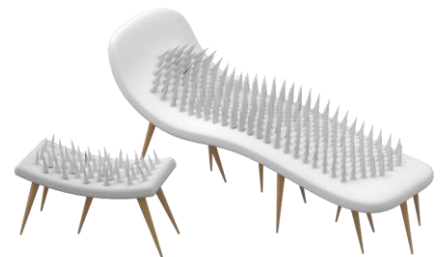

2. Physical Properties

SN-803-2020

PROPERTY	METHOD	TYPICAL RESULT
Specific gravity	DIN ISO 1183	1.74
Weight (12mm Thickness)	-	21 kg/m ²
Flexural Modulus	EN ISO 178	9030 Mppa
Flexural Strength	EN ISO 178	64.5 Mpa
Elongation at break	EN ISO 178	0.83%
Electrical Resistance	EN 61340-5	1*10 ¹² Ω
Thermal Resistance	DIN EN 12664	0.092 m ² K/W
Coefficient of longitudinal expansion	ASTM D696 (Thermal expansion)	3.6 * 10 ⁻⁵ /°C
Thermal conductivity	DIN EN 12664	0.53 W/(m K)
Colorfastness	ASTM G155	See color recommendation
Water absorption	ASTM D570 (24hr)	0.04%
Freeze/thaw resistance	ASTM C666	No effect
Salt fog	ASTM B117	No effect
Sulfur dioxide resistance	ASTM G85	No effect
Fungus and Bacteria resistance	ASTM G21 & G22	No growth

Fire Resistance	METHOD	Result
Euro class (Reaction to fire)	EN 13501-1	B-s1, d0
France	NFP 92-501	M2
Germany	DIN 4102-1	B1

3. Recommended Color for the Exterior

SN-803-2020

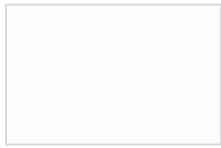

Bright white

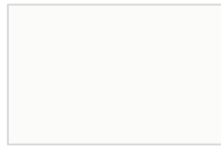

Pure white

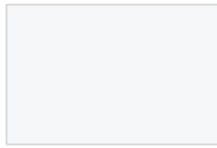

Quasar white



Tusk

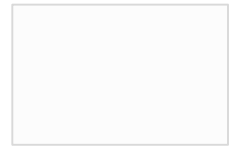

Pearl

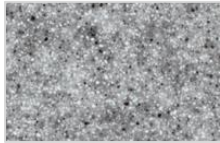

Sanded grey



Sanded sahara



Sanded vermillion

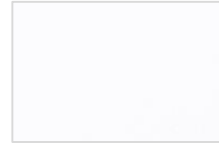

Sanded icicle

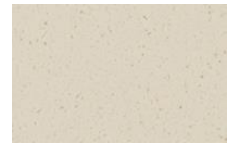

Sanded papyrus

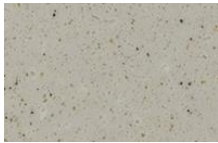

Sanded heron



Sanded white pepper

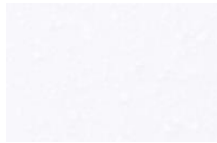

Aspen glacier



Aspen snow

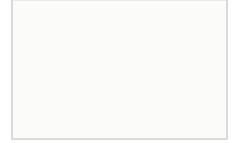

Dazzling white

Before choosing the material for exterior purpose, discoloration due to UV-Radiation is one of the very important issue.

Staron® has performed an accelerated weathering evaluation according to the ASTM G155 test standard on the level of color change when used on the outside for a long period of time and recommends outside usage on 14 colors above based on this evaluation result.

These 14 colors of Staron® above are expected to have 5 unit or less of ΔE , color change value under the condition of outside usage for 10 years.

NOTE: The transmittance of Staron® is vary depending on its thickness and color. The installation should be done in consideration of the transmittance by color. If the transmittance is not a desired effect, please test with a sample prior to installation.

SN-803-2020

1. Staron® Sheet

- Product Dimensions: 760mm (Width) × 3680mm (Length) x 12mm (Thickness)
- Optimum Storage Temperature : 59~73°F (15 ~ 23 °C)
- Storage Conditions : Store indoors (Avoid exposure to sunlight and moisture)
- Selection of Color : Use of recommended colors is suggested for external application.
- Color variation: Sheets may have different colors if the lot no. is different. Only same lot no. of sheet will have same color.

2. Fabrication Equipments

- Table Saw : An equipment that can cut the sheet into a desired size. A circular saw is installed at the bottom of table
- Router : Able to cut into a desired form using a rotating circular saw and able to have smooth edge.
- Sanding machine : A grinding tool. The rotary orbital sanding machine is suitable tool for solid surface.
- Thermoforming Machine : Equipment for thermoforming solid surface. Has advantages of uniform heating and saving time compared to the oven
- CNC : A machine that can carve or cut a desired shape to the board. A joint design of board edge or pattern carving on the used section are possible



< Table Saw >



< Router >



<Thermoforming machine >



< CNC >



< Sanding machine >

1. Polishing

Staron® is able to create a desired gloss such as Matt, Semi gloss or High gloss depending on the sanding method. Please refer to the sanding sequence according to the sand paper below.

Finish	Sand paper grit	Micron-3M	Amralon-Mirka
Matte	120 → 150 → 180 → Scotch bright (RED)	80 → 60 → Scotch bright (RED)	
Semi gloss	120 → 150 → 180 → 220 → 320 → (600 Wet)	80 → 60 → 30 → 15	180 → 360 → 500
High gloss	120 → 150 → 180 → 220 → 320 → (600 → 800 → 1000 Wet)	80 → 60 → 30 → 15 → 9 → 5	180 → 360 → 500 → 1000 → 2000 → 4000

2. Thermoforming

Staron® is a material that enables thermoforming. The sheet gets softly bent if heated for 30~40 minutes under about 160°C and can be modified as a desired form if naturally cooled using the mold. Refer to the technical information "SN- 319" for a detailed thermoforming method

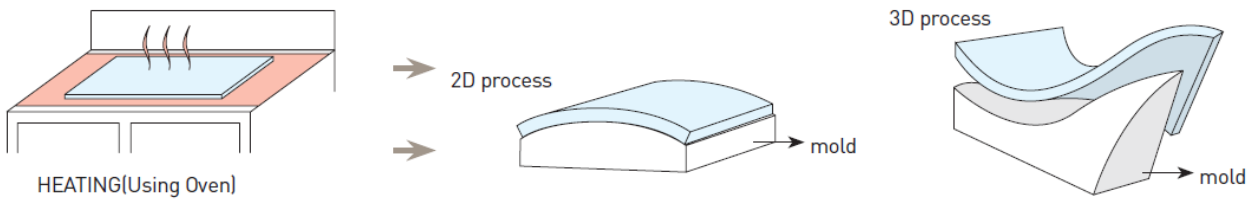

3. Engraving and Inlay

Staron® is easy to fabricate. Texts or designs can be engraved using CNC. The inlay process also can make new pattern by inserting a Staron® of different color to the engraved section.

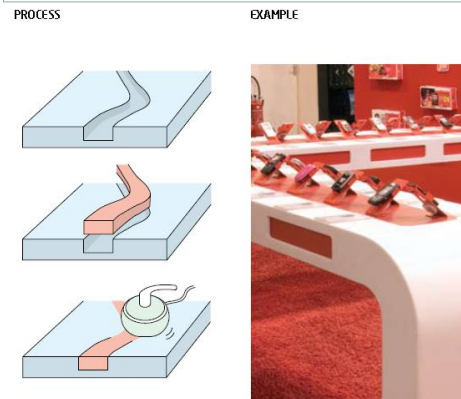
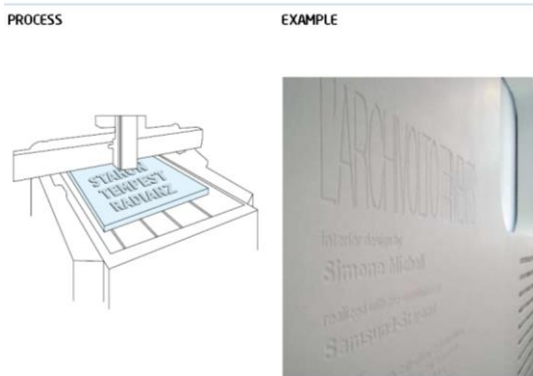

4. Sheet Size and Edge Treatment

The open joint method may show fasteners, etc through joint sections. Please refer to the joint design below to select the most appropriate design for the building. Normally, the thermal expansion gap on the joint is 8~10mm. It can be determined considering the thermal expansion rate according to the size of sheet. Staron® can be seamed without seamless but more than 5 x 5m size is not recommended. Please determine the seaming size of the sheet considering thermal expansion or load. In case of the application of Staron® building façade, please check whether the use of Staron® on such height of building complies with the local regulations or building code.

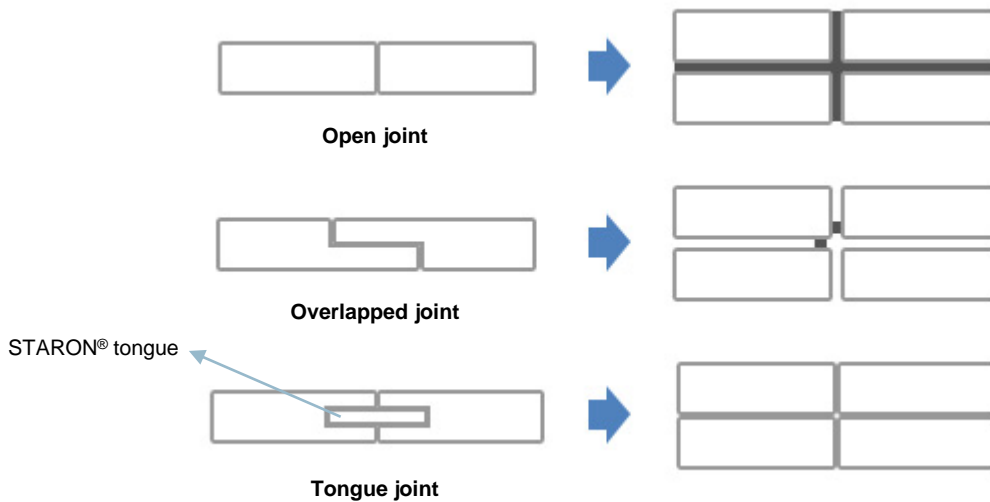

5. Luminous Application

Staron® possesses different light transmittance according to the color. In case light enters through the rear side of board or installing a light source, please verify through a preliminary test before the construction as the stud of rear side may be exposed to the used section.

Staron® wall cladding installation methods is fastening to the wall with anchor or mounting with high performance adhesive. The method of fastening with a specially devised undercut anchor is normally used in case of powerful fastening is required. On the other hand, the instance of using adhesive is limited to the places where the height of building is low without problems such as vibration.

The external wall is directly affected by the open air environment such as rainwater and temperature change. The ventilated facades where air can be circulated at the rear side of Staron® sheet is more advantageous because the gap between the wall and the staron sheet provides a thermal insulation effect as well as a ventilation area to discharge moisture by blocking outside weather.

1. Advantages of Ventilated Façade System

- Discharges the rainwater flow in from the outside and the moisture created from the inside of building through the gap to prevent corrosion of the building
- Saves energy of the building through increased thermal insulation effect
- Reducing external noise
- Prevents dew condensation on the building structure.

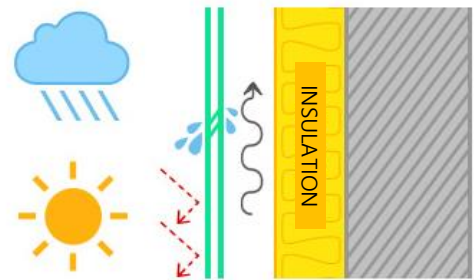

2. Anchoring System

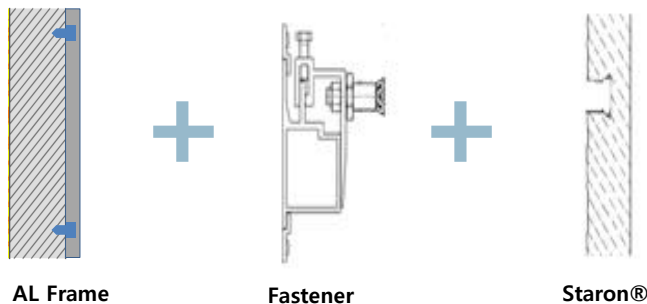

3. Aluminum Frame substructure

For the frame substructure, lightweight alloy 6060 aluminum material with outstanding flexibility and corrosion resistance is more widely used than steel material.

Selecting proper substructure for the project is need consider the condition and the design of building. It is recommended to be advised from specialized company that possesses various experiences and specialized technology. considering the condition and the design of building for the selection of material.

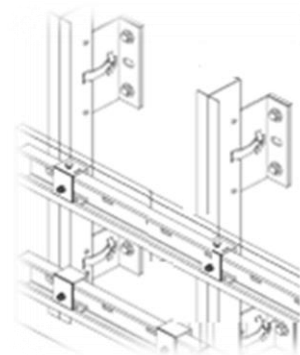

4. Fasteners

Fasteners are composed of under cut anchor and aluminum angle. Under cut anchor is a metal inserting into Staron® directly and fixed it mechanically. Aluminum angle is for connecting undercut anchor and substructure frame.

There are various anchor types and dimensions, separation specifications by each anchor manufacturer. Please select proper anchor type considering the quality, estimated cost and workability required for the wall construction project.

5. Under cut Hole Drilling

The rear side drilling is required in order to fasten under cut anchor to the sheet. It is important to use an exclusive drilling machine for stable fastening. The location of anchor where it drilled on the sheet must not exceed 100mm from the edge of Sheet. The distance between anchors should not be exceed 560mm.

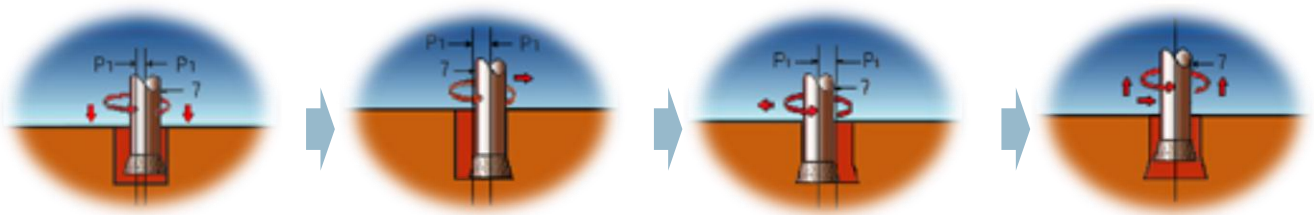

Drilling Equipment

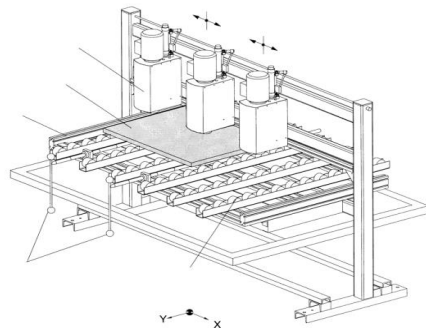

Under cut anchor

There are various types of under cut anchors by manufacturer and the designs are shown as below.



KEIL



Fischer



DFP

Anchor Setting Tool

Please fasten using an exclusive under cut anchor tool while fastening the anchor.



6. Cases Studies of Installation Systems

There are various methods of installing the sheet to the external wall. Before selecting the installation system, please examine the local climate condition and the structure of building to install with a professional architect.

Case 1. Ventilated Façade System - BWM

A typical Solid surface external wall construction method. It is attaching Staron® on stable AL frame.

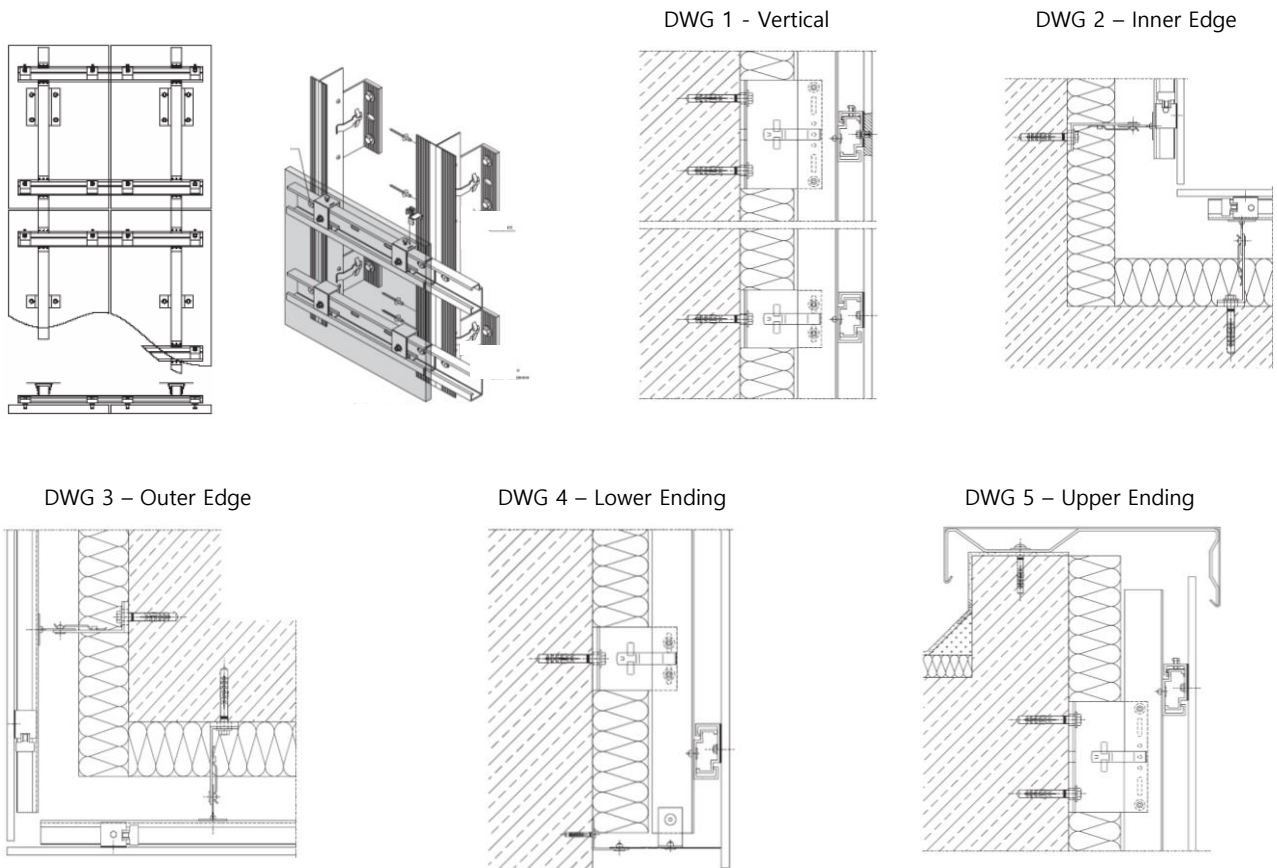

Case 2. Ventilated Façade System – DFP

An anchor system without AL frame. The cost is low compared to the BWM system but leveling skill is necessary without AL frame.

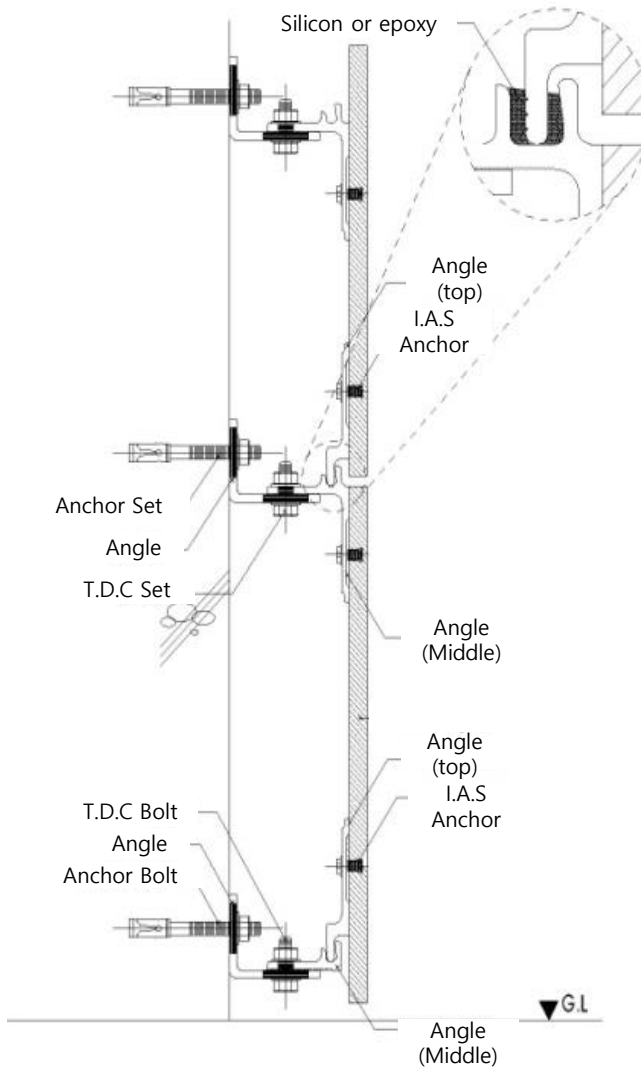

DWG 1 – Anchor Assembly

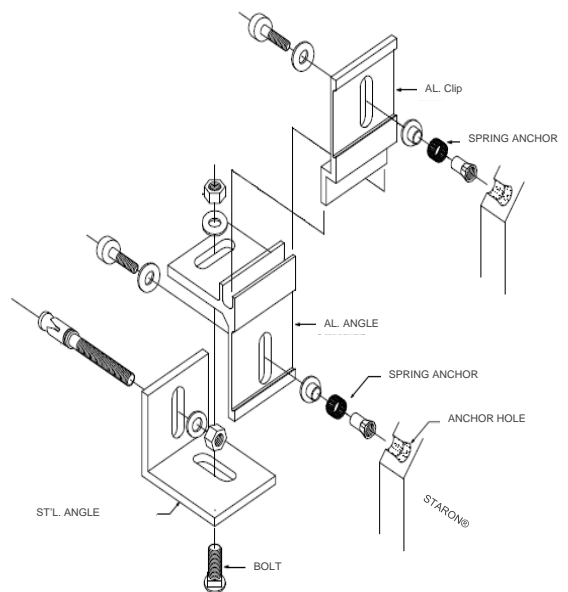

Maintenance of Staron[®] Exterior Wall Cladding

Staron[®] is a product that possesses very outstanding stain resistance and chemical resistance so that most contaminants can be easily removed. The main stain sources are the contaminants discharged from automobiles and industrial facilities while these contaminants have adsorbability to easily contaminate the building surface.

Normal contaminations are removed using neutral detergent and water while severe contaminations can be removed through sanding. As a periodic external wall cleaning method, cleaning by water-driven system with high pressure (2,800psi or less pressure) is recommended. With the water-driven system use eco-friendly neutral detergents for normal cases and use baking soda in case the contamination is severe. Water-driven system with high pressure can quickly and uniformly clean the wide area and able to minimize cleaning time than the sanding process.

As the level of contamination is easily shown as the color used gets brighter and greatly affected by the atmospheric environment, please set the cleaning cycle considering these things.

European Technical Assessment (ETA-16/0091 of 30 March 2017)

DIBT (Deutsches Institut für Bautechnik, Technical Assessment Body certified by European Organization for technical approvals) issued ETA document for Staron[®] Exterior cladding with Keil undercut anchor system. It has been verified following ETAG 034 (Guideline for European Technical Approval of kits for external wall claddings)